

POCKET

 **Diemme**

# indice

## index

AIRA	98. 99
ARIEL	86. 87
AUCKLAND	122. 127
BONN	78. 81
CIRCUIT	54. 61
CROSS	50. 53
DOUBLE	62. 65
DUBLINO	166. 167
DUKE	146. 147
EON	4. 17
FIT	152. 153
FIVE	162. 163
FLASH	154. 155
FRAME	68. 69
FREE	164. 165
GOAL	156. 161
HALFPIPE	106. 113
ICE	92. 93
JAZZ	46. 47
KEY	149. 151
LIZ (divano/sofa)	70. 71
LIZ (poltroncina/armchair)	18. 19
LIZ (sedia ufficio/office chair)	138. 141
MARVEL	38. 39
MISS	24. 29
MISS LOUNGE	30. 31
MISTER	34. 35
MOON	114. 119
NEST	136. 137
ORIGAMI	42. 45
OXFORD	100. 103
PASS	40. 41
PRINCE	76. 77
QUEEN	120. 121
RING	168
SMART	148. 150
SOCIAL	94. 97
SQUARE	72. 73
STAR	132. 135
STYLE	128. 131
SUNNY	82. 85
TOFFEE	66. 67
TRONIX	36. 37
VANITY	20. 23
VENUS	142. 145
YOGA	48. 49
YPSILON	32. 33
ZETA	88. 91





EON





EON



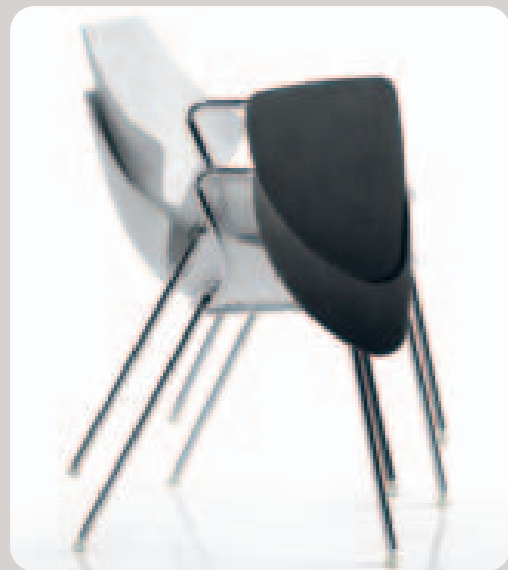

EON



EON





EON







EON





LIZ





VANITY





VANITY



MISS



MISS





MISS







MISS LOUNGE





YPSILON



MISTER

MISTER





TRONIX





MARVEL

PASS



ORIGAMI





ORIGAMI



ORIGAMI

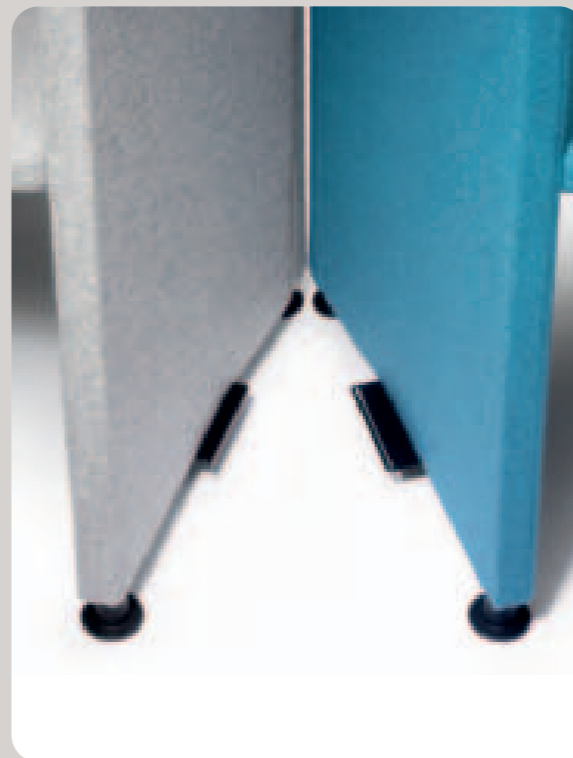



JAZZ





YOGA



CROSS





CROSS





CIRCUIT



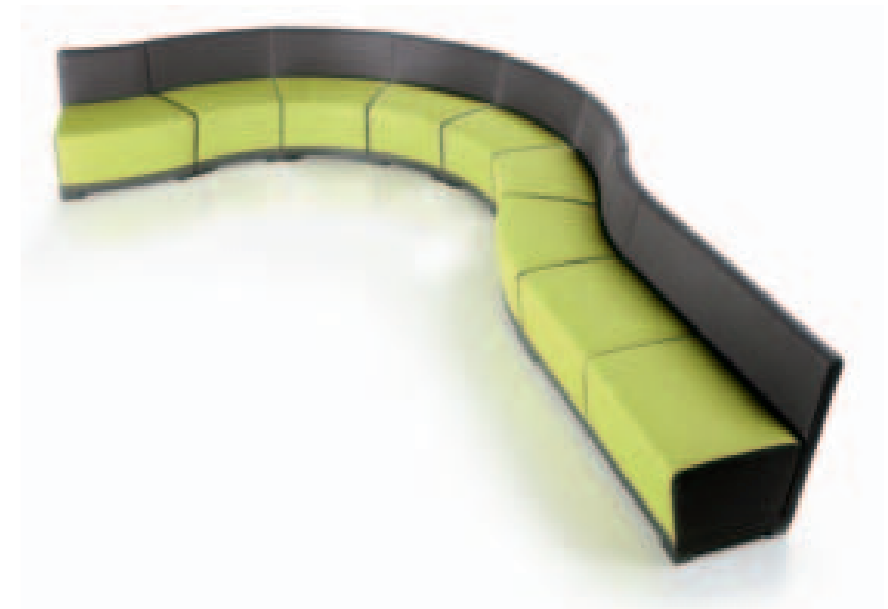



CIRCUIT





CIRCUIT TABLE



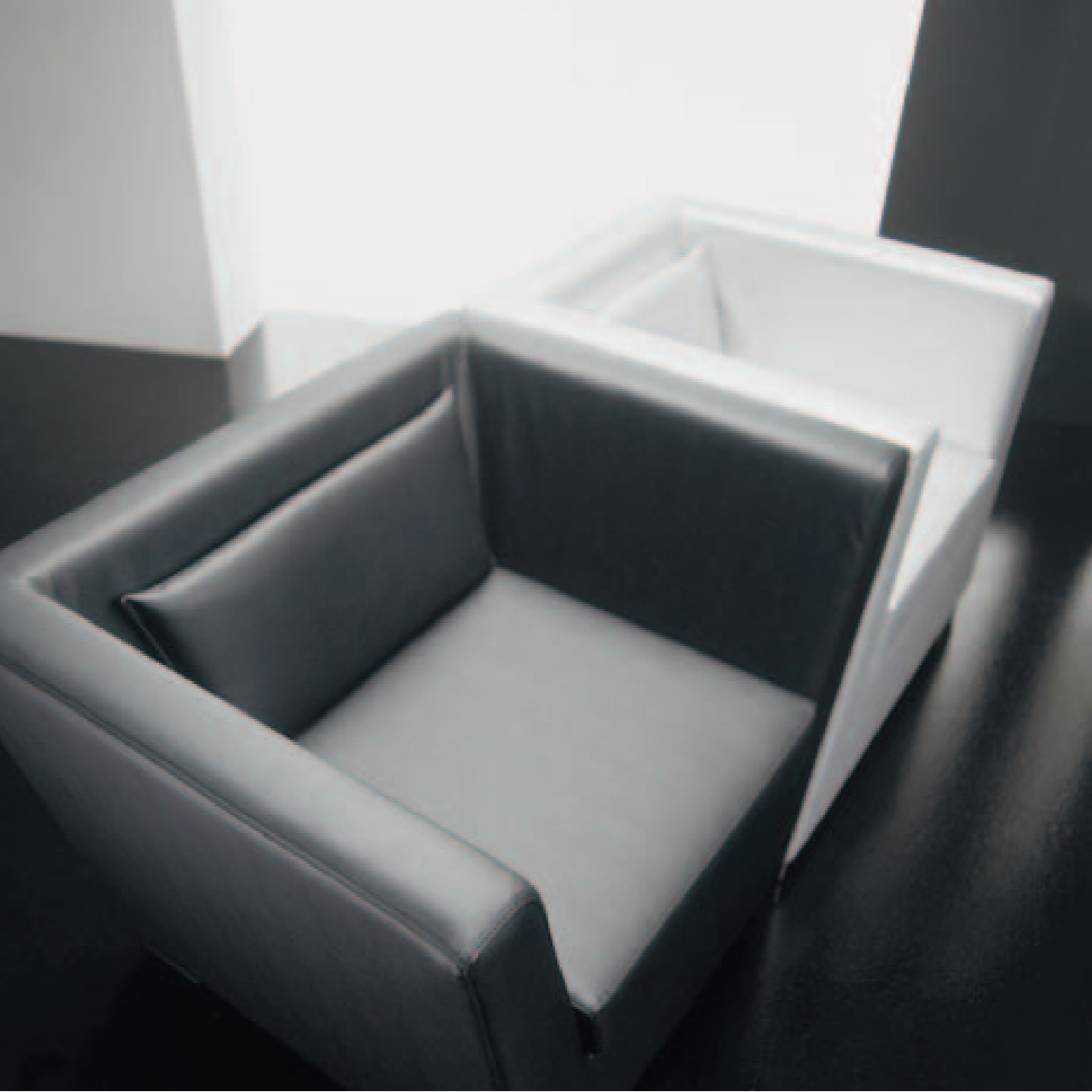

DOUBLE





DOUBLE



TOFFEE



FRAME





Z11



SQUARE

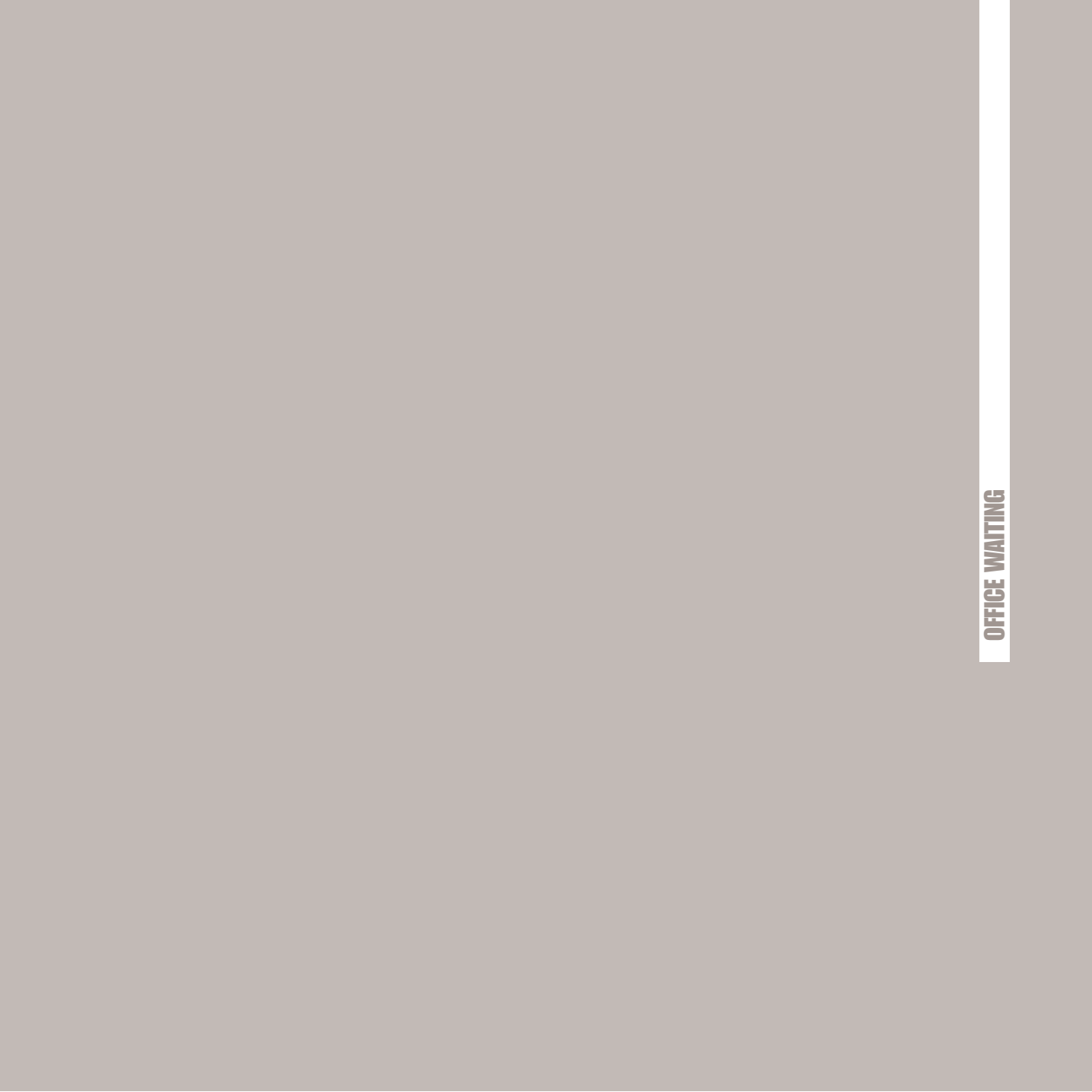



PRINCE





**BONN**

BONN



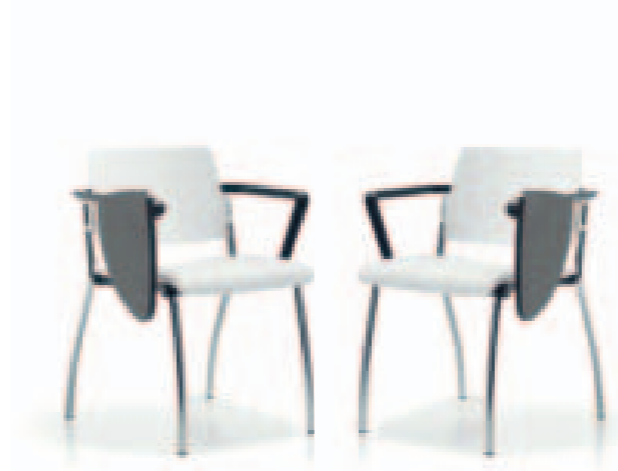

SUNNY



SUNNY





ARIEL



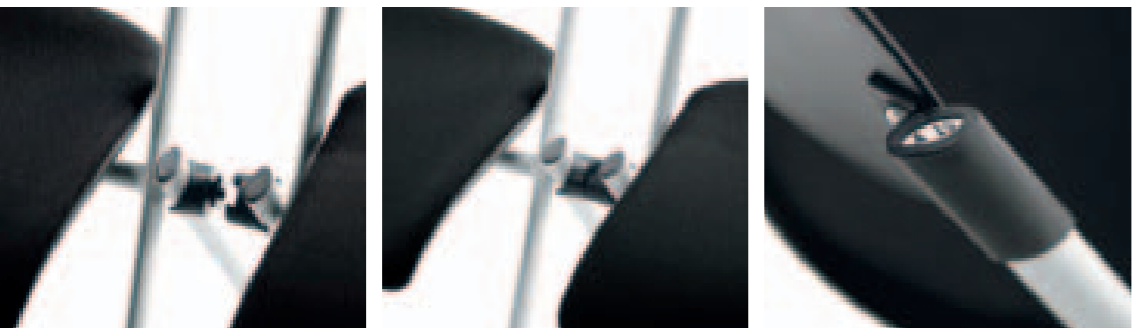

ZETA



ZETA

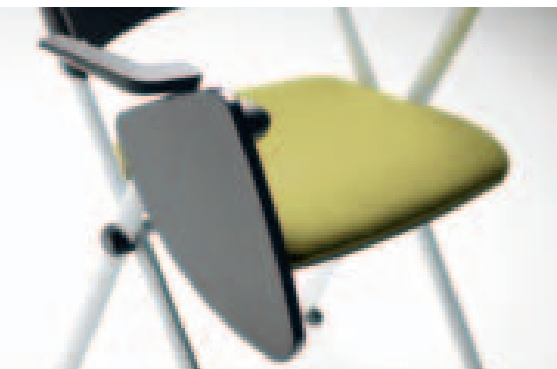





**SOCIAL**





SOCIAL







OXFORD



OXFORD



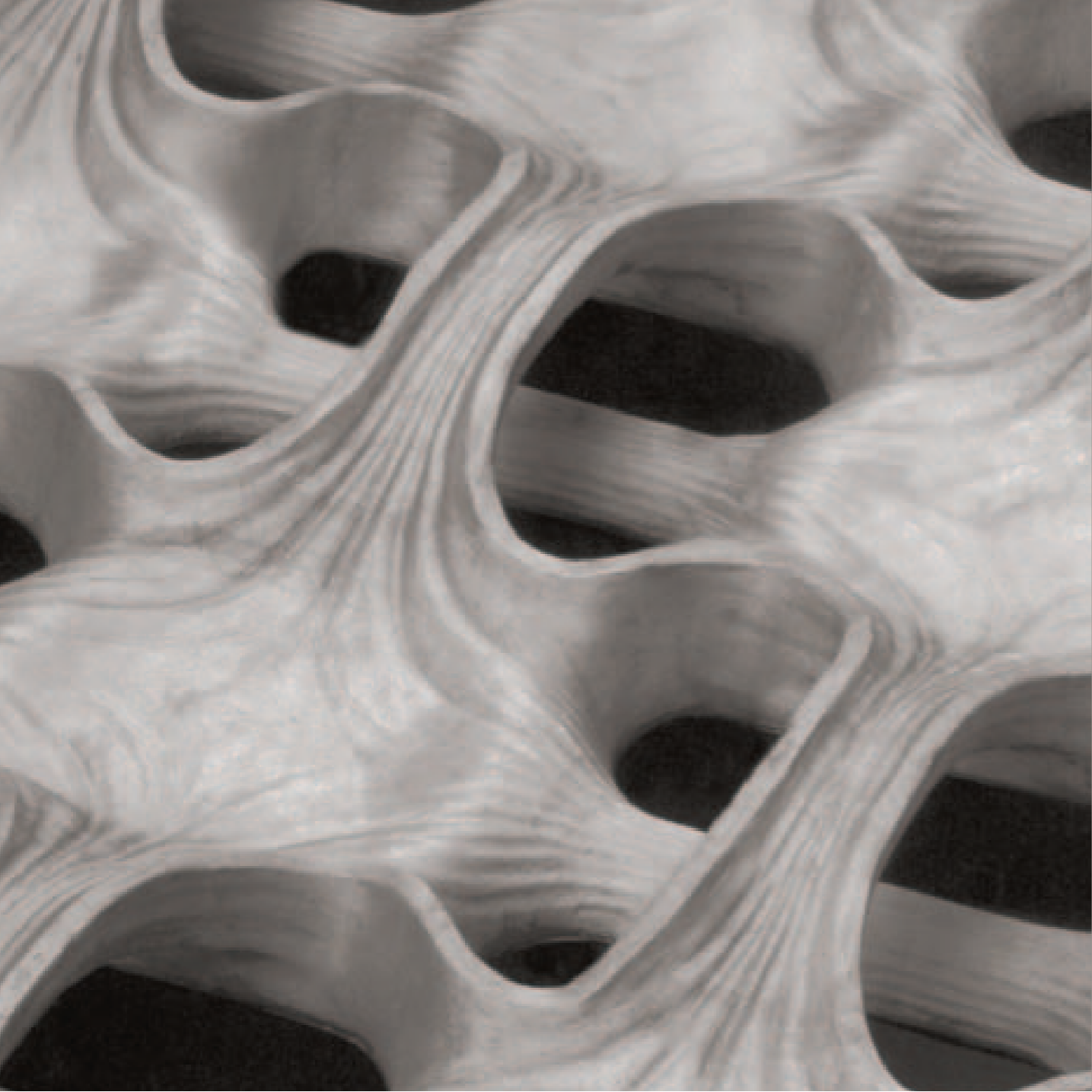

HALFPIPE





## HALFPIPE







HALFPIPE



HALFPIPE





As awarded by The Chicago Athenaeum:  
Museum of Architecture and Design.



**MOON**









QUEEN





AUCKLAND





AUCKLAND

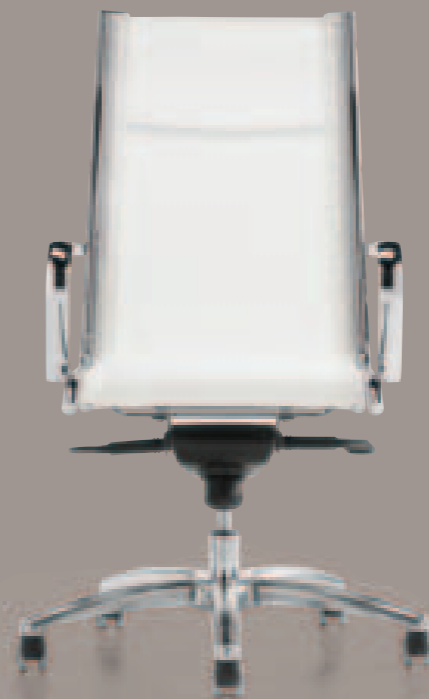





**AUCKLAND**





STYLE





STYLE

STAR





STAR





NEST



LIZ





LIZ







VENUS



VENUS







SMART

KEY







**FIT**







GOAL







GOAL



GOAL



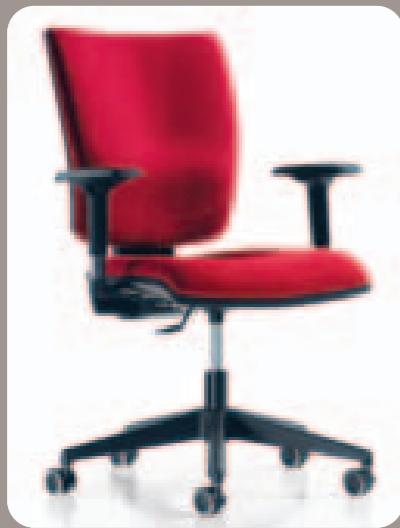

FIVE

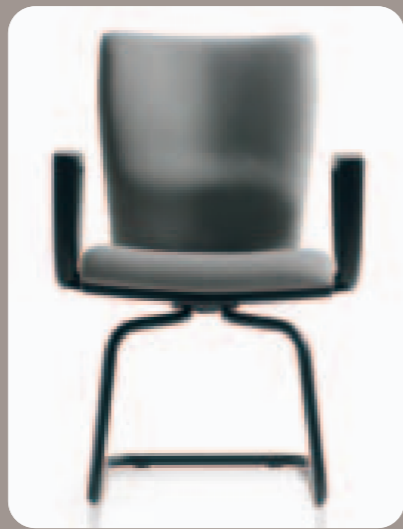
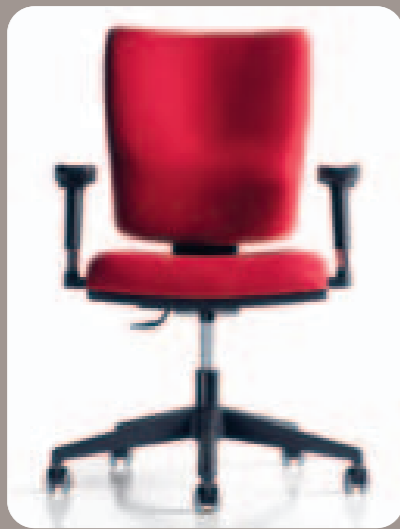

FREE



DUBLINO



RING



**upholstery**  
rivestimenti

PLANET - CAT. F



JET - CAT. F



TREVI - CAT. G

BINGO ELAST / MIRAGE - CAT. G



CUBE - CAT. G





MODEL - CAT. S



EXTREMA AU - CAT. TOP



**SILK - CAT. TOP**



**PELLE FIESTA**



**PELLE NUVOLA**

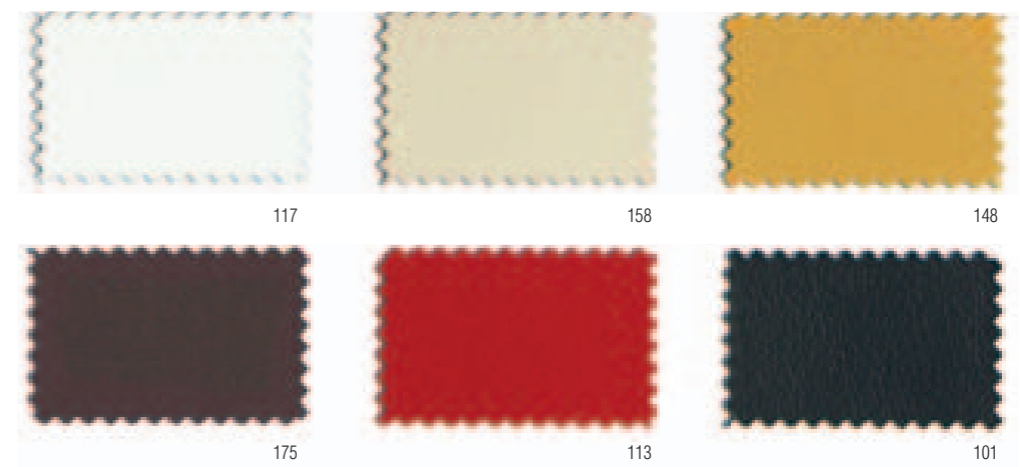

**RETI: AUCKLAND / SUNNY**



301

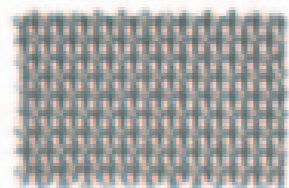

601

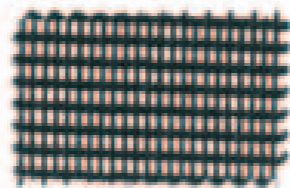

651

**RETI: FLASH / GOAL / NEST / SOCIAL / SUNNY**

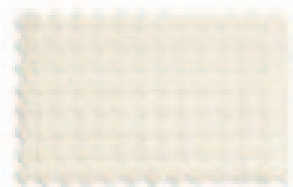

1001

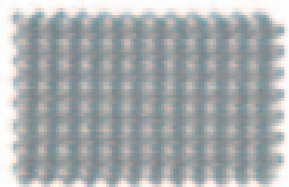

8043

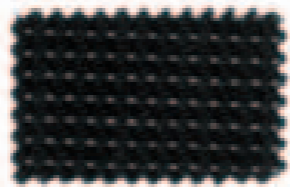

8033

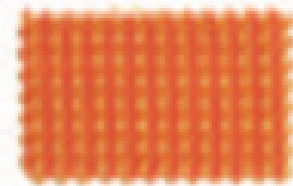

3029

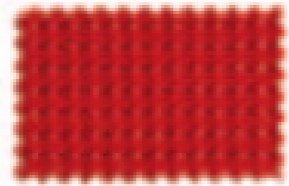

4008

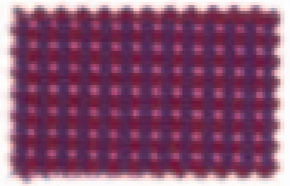

4016

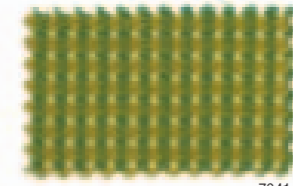

7041

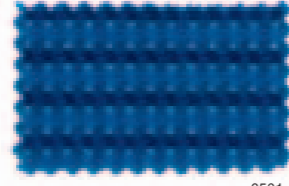

6501

**technical details**  
caratteristiche tecniche

**AIRA**

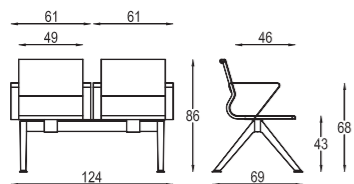

Panca in lamiera microforata, verniciata grigia, da 2, 3 o 4 posti. Ideale per zone attesa, anche di spazi pubblici, come aeroporti. Scocca unica, con o senza braccioli. Optional: tavolino in lamiera.

Bench in metal structure, grey varnished finish, from 2 to 4 seater. Perfect for waiting areas, even of public spaces, as airports. Only shell, with or without arms. Optional: table.

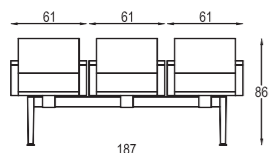

Banc en métal vernis gris, 2 - 3 - 4 places. Idéal pour les espaces publics comme les aéroports. Avec ou sans accoudoirs. Accessoire: table.

Bancada en metal, varnizada gris, de 2, 3, 4 asientos. Ideal para las zonas de espera, también para espacios públicos, como los aeropuertos. Carcasa única, con o sin brazos. Optional: mesa.

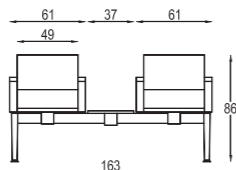
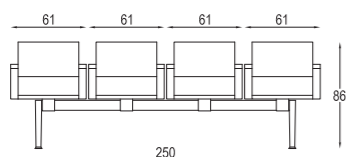

**ARIEL**

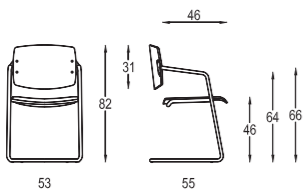

Seduta visitatore, schienale in polipropilene nero o bianco, o imbottito o in rete nera, sedile imbottito in poliuretano espanso e rivestito. Telaio slitta verniciato alluminio o cromato, con braccioli fissi. Impilabile.

Visitor chair, backrest in black or white polypropylene, or padded or in black mesh, seat padded in polyurethane foam and upholstered. Cantilever frame in aluminium varnished color or chromed, with fixed arms. Stackable.

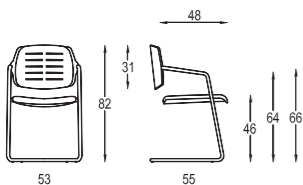

Fauteuil visiteur, dossier en polypropylène blanc ou noir, ou rembourré ou en resille noir, seance rembourré en polyuréthane, Structure patin chromé ou peint en gris, avec accoudoirs fixes. Empilable.

Silla confidente, respaldo en polipropileno negro o blanco, o acolchado o en red negra, asiento acolchado en poliuretano. Estructura varnizada aluminio o cromada, brazos fijos. Apilable.

**AUCKLAND**

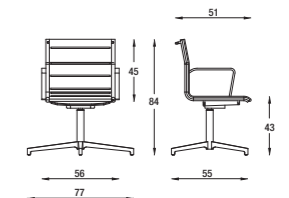

Stylish designed armchair for managers, executives and visitors; comfortable and strikingly versatile, perfectly suited to different working environment. Characterized by the grey, white or black mesh-net seat and back. Also available fully upholstered. Aluminium base and arms, gaslift or chromed sled frame or 4 aluminium blades frame with return mechanism.

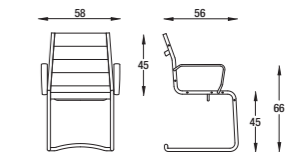

Sillón de diseño elegante para presidentes, directivos y visitantes; confortable y muy versátil, perfecto para diferentes ambientes de trabajo. Caracterizado por un respaldo y un asiento de red negra, blanca o gris. Disponible también en versión todo revestida. Brazos y base de aluminio, elevación a gas o con base trineo cromada, o con base de 4 radios en aluminio con mecanismo de retorno automático.

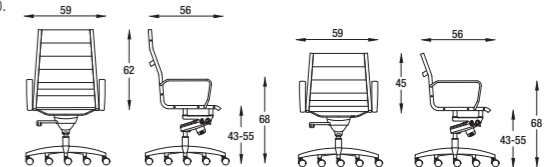

**BONN**

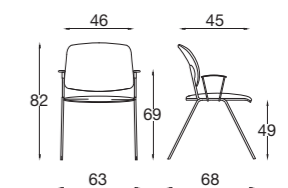

Stackable chair with and without armrest, also available in a bench from 2 to 5 seater, with different optional (writing tablet, trolley and tray). The seat and backrest are padded and upholstered, or they are available even in wood and polypropylene. The 4 legs frame and armrests are either varnished black or chromed.

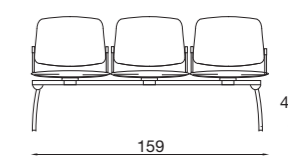

Silla apilable, con o sin brazos, disponible también en la versión de barra de 2 a 5 asientos. Con diferentes opcional: mesa de escritorio, llano de apoyo, cesta bajo del asiento. El asiento y el respaldo pueden ser acolchados en poliuretano o de madera de haya o en polipropileno. La estructura de 4 patas y los brazos pueden ser barnizados negros o cromados.

Poltrona presidenziale, direzionale e visitatore dal design raffinato; confortevole e dalla spiccata versatilità, perfettamente idonea a più ambienti lavorativi. Caratterizzata dallo schienale e sedile in rete nera, bianca o grigia. Disponibile anche nella versione tutta rivestita. Braccioli e base in alluminio, elevazione a gas o su base slitta cromata o su telaio 4 razze in alluminio, con meccanismo di ritorno.

Sedia impilabile multiuso con o senza braccioli disponibile anche nella versione su barra da 2 a 5 posti, corredata da vari e funzionali accessori (tavoletta per scrittura, cestello sottosedile, piani d'appoggio). Seduta e schienali possono essere imbottiti in poliuretano espanso, in legno di faggio o in polipropilene. Il telaio a 4 gambe ed i braccioli possono essere verniciati nero o cromati.

Chaise empilable avec ou sans accoudoir, disponible également dans la version sur barre de 2 à 5 places équipée de différents accessoires (tablette écrite, panier sous le siège, plan d'appui). Le siège et le dossier sont rembourrés en polyuréthane expansé; aussi disponible dans la version en bois au polypropylène. La structure et les accoudoirs peuvent être vernis en noir ou chromé.

**CIRCUIT**

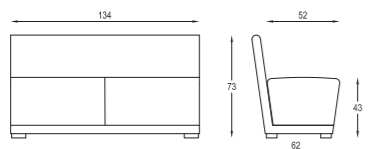
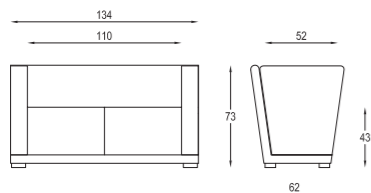
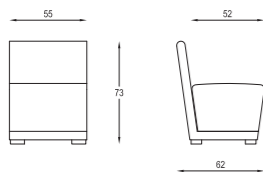
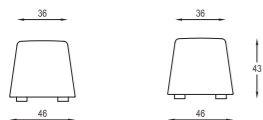

Un concept dalle infinite possibilità. Interni in legno e imbottitura in poliuretano espanso. Comprende la poltrona, il divano due posti e una serie di elementi di varie dimensioni e altezze, lineari o curvi, che uniti tra loro formano composizioni originali adatte ad ogni tipo di spazio e layout.

Un concept de possibilités infinies. Structure en bois rembourrée en mousse polyuréthane. Disponible la fauteuil, le canapé deux places et un certain nombre d'éléments de différentes mesures et hauteurs, droites ou courbes, à utiliser pour former des des compositions originales adaptées à tous les types d'espace et disposition.

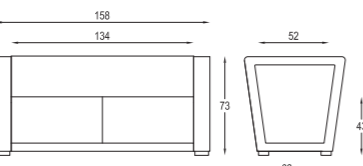
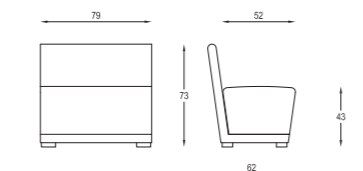

A concept of countless configurations. Inner in wood and padding in polyurethane foam. It includes the armchair, the two-seater settee, and a series of variously sized curved and straight elements which can be linked up together to form original layouts suited to every type of workspace and waiting area.

Un concepto de posibilidades infinitas. Composicion de madera y acolchado de poliuretano. Disponible la butaca, el sofa 2 asientos y una serie de diferentes elementos curvos o lineares que puestos juntos crean composiciones originales para cualquier tipo de espacio y lugar.

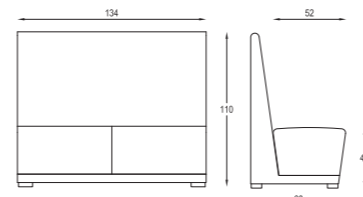

**CROSS**

Divano componibile, dalla forma elegante e originale. Struttura interna i in legno e imbottitura in poliuretano espanso ad alta densità.

Modular sofa, with an original and smart design. Structure in multilayer beech wood and padded in polyurethane foam.

Canapé modulaire, à la forme original et élégante. Structure en multiplis et bois aggloméré recouvert d'une mousse indéformable de polyuréthane et doublée de fibres de polyester.

Sofà modular, de forma elegante y original. Estructura de haya y acolchado con poliuretano de alta densidad.

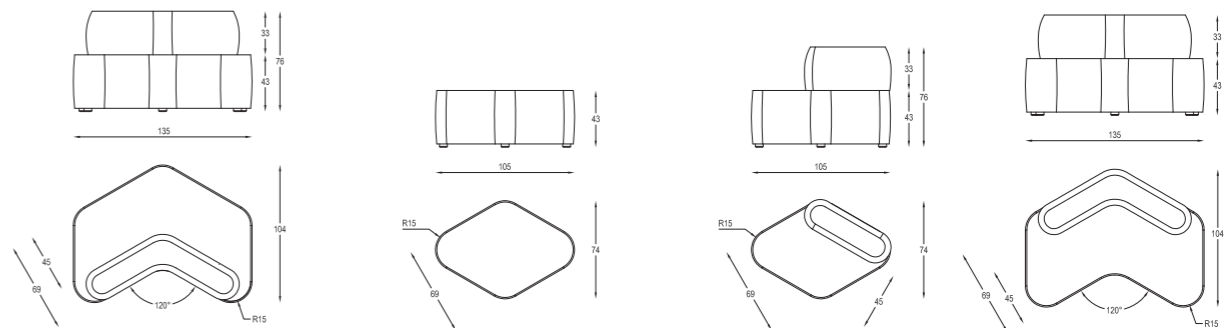

Poltrone dalla forma elegante, caratterizzate da una perfetta linea di aderenza per l'accostamento l'una con l'altra. Con struttura in multistrato di legno imbottito in poliuretano espanso. Piedini in acciaio alluminio lucido. Disponibile anche divanetto 2 posti.

Snugly interlocking elegant armchairs with structure in multilayer beech wood, padded in polyurethane foam. Chromed steel feet. Available also as two-seater sofa.

Fauteuil à la forme élégante, caractérisée d'une parfaite ligne d'adhérence pour le rapprochement l'une avec l'autre. La structure est en hêtre multi-couche recouvert de polyuréthane expansé. Petits pieds en aluminium brillant moulé sous pression. Aussi disponible le canapé 2 places.

Sillón de la forma elegante, caracterizados por una línea perfecta procedente del acercamiento de los mismos. Con estructura en multistrato de madera revestido por poliuretano esponjoso. Pies en acero aluminio lustre. Disponible también el sofá con doble asiento.

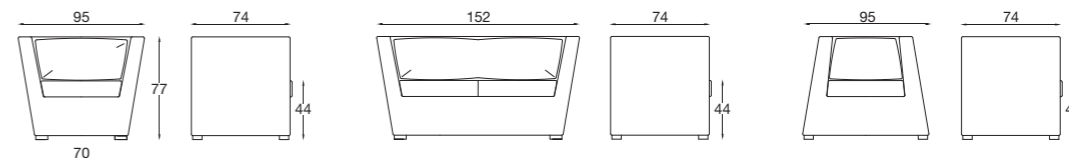

**DOUBLE**

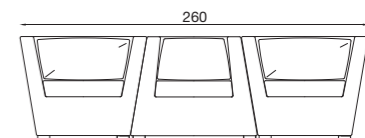
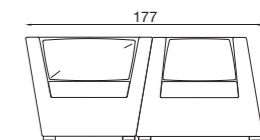

DUBLINO

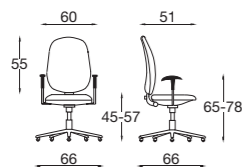
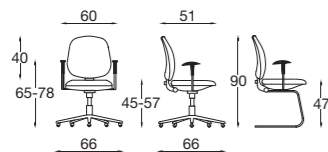

Serie di sedute dattilo con schienale alto o basso, comunque oscillante, regolabile in altezza e bloccabile in qualsiasi posizione. Disponibile nelle versioni ad elevazione gas con contatto permanente, con meccanismo sincronizzato di oscillazione oppure a slitta verniciata nero con contatto permanente. E' caratterizzato da due tipi di bracciolo: fisso in nylon nero, regolabile in altezza ed orientabile in nylon nero. Disponibile anche nella versione sgabello.

Série de sièges dactylo avec dossier haut ou bas bas, oscillant, réglable en hauteur, ils peuvent être bloqués dans n'importe quelle position. Disponibles dans les versions à élévation à gaz avec contact permanent, ou avec un mouvement synchron, ou bien à coulisse vernie en noir avec contact permanent. Ils sont caractérisés par deux types d'accoudoir: fixe en nylon noir, réglable en hauteur en nylon noir. Egalement disponible en version tabouret.

Range of chairs for typists with tall and low backrest, all oscillating, and with adjustable height; they may be fixed in any position. Available with gas height adjustment mechanism with permanent contact, synchronized mechanism or black varnished cantilever frame with permanent contact. The chair comes with two types of armrests: fixed in black nylon or height-adjustable and swivelling in black nylon. Also available in stool version.

Serie de sillas dactilo con respaldo alto o bajo, en todo caso oscilante, ajustable en altura y bloqueable en cualquiera posición. Disponible en las versiones a elevación gas con contacto permanente, con mecanismo sincronizado de oscilación o bien a trineo barnizado negro con contacto permanente. Es caracterizado por dos tipos de brazo: fijo de nylon negro, ajustable en altura y orientable de nylon negro. Disponible también en la versión taburete.

DUKE

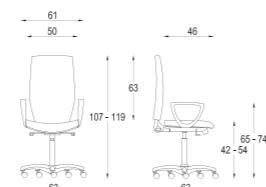
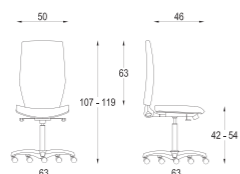
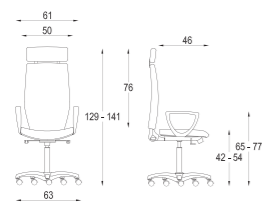
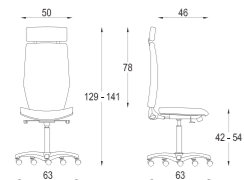

Poltrona direzionale, con schienale medio o con appoggiatesta, caratterizzata dalle linee eleganti e dal massimo comfort. Scocca in multistrato di faggio, imbottita in poliuretano espanso. Meccanismo sincron, con base 5 razze in nylon nera o in alluminio, su ruote autotrenanti e gommate. Optional: 4 tipi di braccioli: in polipropilene fissi bianchi o neri, fissi in poliuretano nero, regolabili in polipropilene nero.

Fauteuil de direction ou de présidence, caractérisés par une ligne classique et élégante. Coque en hêtre, rembouré en polyuréthane. Disponibles avec mécanisme synchron; option des accoudoirs fixes en nylon noir ou blanc, en polyuréthane noir ou réglables. Base à 5 rayons en nylon noir, sur roulettes.

Executive armchair, extremely comfortable, with medium backrest or headrest. Multilayer beech wood shell, padded in polyurethane foam. Synchronized mechanism on 5 star black nylon base or aluminium, on rubber castors. Optional: 4 kind of armrests: fixed, in polypropylene black or white, fixed in black polyurethane, adjustable in polypropylene.

Sillon directivo, caracterizado por una linea elegante y ergonomica. Respaldo medio o con resopacabeza. Estructura de madera de haya y acolchada. Mecanismo sincronizado, con base 5 radios negra o de aluminio con ruedas engomadas. 4 tipologias de brazos, fijos de polipropileno negro o blanco, fijos de poliuretano negro, ajustables de polipropileno.

EON

Sedia ideale per il mondo contract, ufficio e per il settore casa. Scocca in poliuretano rigido TECH, colorato. Disponibile su telaio 4 gambe cromato, su telaio slitta cromato, su gas e base a 5 razze in alluminio con ruote o su telaio girevole in tubolare d'acciaio. Versione su panca da 2 / 3 / 4 posti. Sgabello fisso con telaio cromato o con gas e base rotonda cromata. La scocca può essere anche imbottita e rivestita.

Chaise pour la maison et le bureau. Coque de polyuréthane rigide TECH, de couleur. Disponible avec piétement à 4 pieds chromé, avec châssis glisse chromé, avec gaz et 5 rais d'aluminium sur roulettes. Eon est conçue même pour les bancs, de 2 à 4 places, et le tabouret sur base fixe ou gaz. La coque peut être rembourré et tapissé.

Chair perfect for contract, home and office areas. Shell in rigid TECH polyurethane, colored. Available with 4 chromed legs frame, with cantilever frame, with gaslift and 5 star aluminium base on castors and 4 star tubular swivel frame. Eon is conceived even for benches, from 2 to 4 places, and stool on fixed or gaslift base. The shell can be padded and upholstered.

Silla, ideal por el sector contract, el hogar y la oficina. Estructura de poliuretano rigido TECH colorado. Disponible con 4 patas cromadas, patin cromado, con elevacion a gas y base a 5 radios de aluminio fundido y ruedas o con base en tubular de acero cromado, giratoria. Eon sale también como bancada de 2 a 4 asientos y como taburete a gas o fijo, con estructura cromada. La silla puede ser acolchada y tapizada.

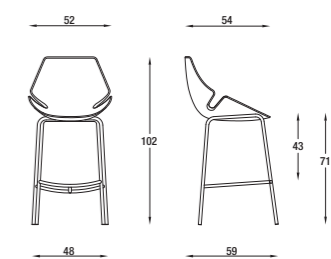
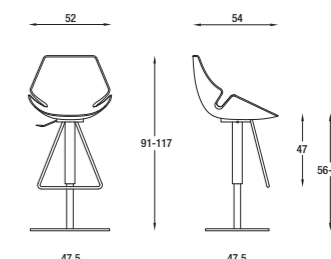
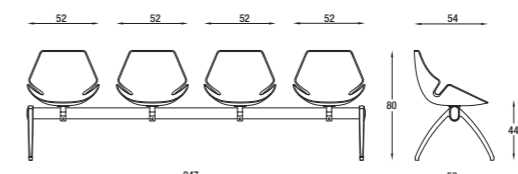
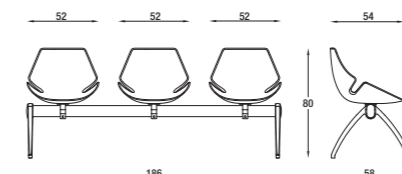
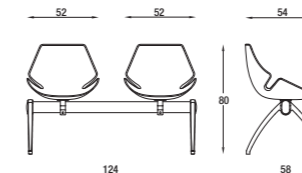
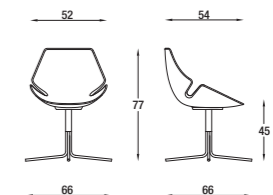
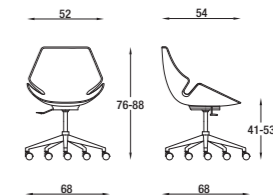

**FT**

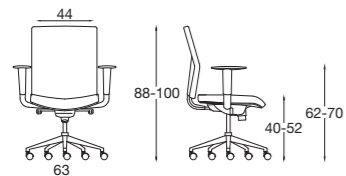

Seduta semidirezionale, versione con schienale alto e medio, imbottita in schiumato a freddo, meccanismo sincron, braccioli regolabili e base a 5 razze in nylon nero o in alluminio pressofuso lucido, su ruote. Disponibile la versione visitatore con telaio 4 gambe cromato.

Executive chair, high and medium backrest version, injected foam padding, synchron mechanism, adjustable armrests and 5 star black nylon or polish aluminium base on castors. Available visitor model with 4 legs chromed frame.

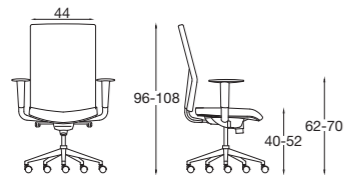

Fauteuil directionnel, avec structure indéformable en mousse à froid, le support lombaire réglable en hauteur. Base en aluminium ou nylon noir, avec accoudoirs réglables. Disponible aussi en version visiteur sur châssis à 4 pieds.

Silla de directivos, caracterizada por una linea ligera. Acolchada en espumado frio, la base es en nylon negro o en aluminio a 5 radios y con ruedas, mecanismo sincronizado, brazos ajustables en acero y poliuretano. Silla de confidente, con estructura cromada 4 patas.

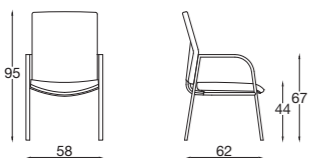

**FIVE**

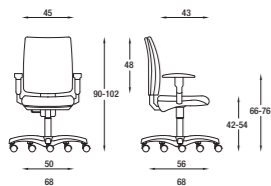

Sedia operativa, base nylon nera di serie, con braccioli fissi o regolabili. Disponibile in versione a gas contatto permanente, sincron o come visitatore su telaio slitta. La serie comprende anche lo sgabello.

Task chair, with standard black nylon base. With fixed or adjustable arms; with permanent contact gas-lift, or synchron mechanism or as visitor chair with cantilever frame. Even the stool is included in this collection.

Poltrona, divano 2 e 3 posti, con struttura in multistrato di faggio, imbottitura in poliuretano espanso ad alta densità. Piedini in alluminio.

Armchair, 2 and 3seater sofa with structure in multilayer beech wood, and polyurethane padding. Aluminium feet.

Série de séances dactyle. La base est en nylon noir, avec accoudoirs fixes ou réglables. Disponible en version à gaz ou synchron.

Serie de sillas dactilo. Base nylon negra. Con brazos fijos o ajustables. Disponible en versión gas o synchron, y confidente con patin o taburete operativo.

Fauteuil, canapé 2 places ou 3 places. Structure en hêtre et rembourré en polyuréthane. Pies de aluminium.

Sillón para la sala de espera, sofá de 2 o 3 asientos con estructura en multistrato de haya, acolchado de poliuretano esponjoso. Pies de aluminio.

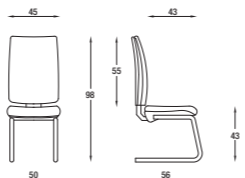
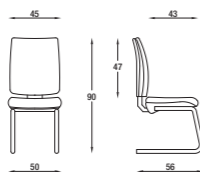
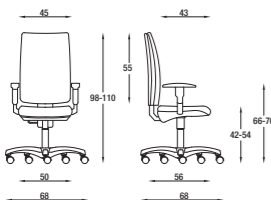

**FLASH**

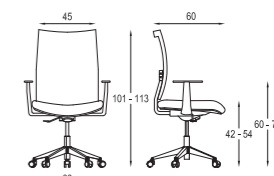

Task chair, high backrest with ergonomic mesh-net and lumbar support, adjustable in height. Seat padded in polyurethane foam and upholstered. Synchronized mechanism. 5-star black nylon base and optional in polished aluminium, on rubber and self-braking castors. 3 kind of armrests: fixed in polypropylene or in soft black polyurethane oval shaped, or adjustable in height. Available in 8 colors of mesh.

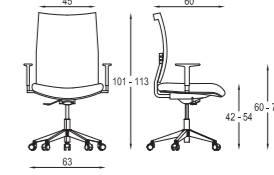

Silla caracterizada por un respaldo de estructura metálica y polipropilene, tapizado con una malla ergonómica e indeformable, en 8 diferentes colores, lleva soporte lumbar ajustable en altitud. El asiento está acolchado y tapizado. Mecanismo de gas con movimiento sincronizado. Base a 5 radios de nylon negro o de aluminio, con ruedas engomadas. 3 tipologías de brazos: fijos at de polipropileno negro, fijos ovales de poliuretano negro, ajustables con partes de metal y apoyabrazos de poliuretano blando.

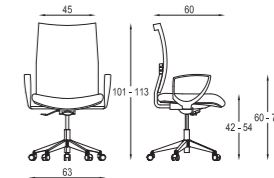

**FRAME**

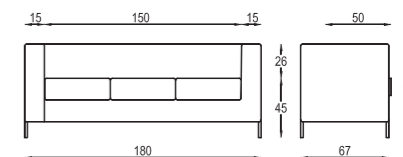
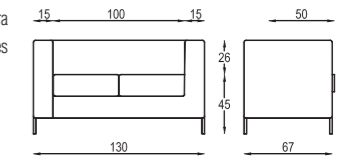
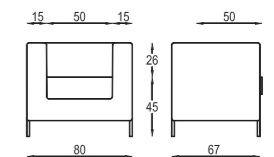

FREE

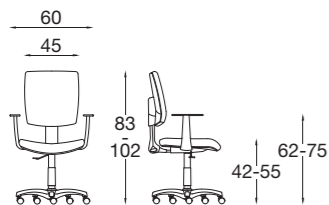

Serie di sedute dattilo con plastiche grigie, senza cuciture. Base nylon grigia di serie, con braccioli fissi grigi o regolabili. Disponibile in versione a gas o sincron.

Range of operator chairs in grey plastic, and seamless. Grey nylon base is standard, but aluminium base is also available; with fixed or adjustable arms; with gas-lift or synchron mechanism.

Série de séances dactyle avec plastiques grises, sans coutures. La base est en nylon gris, avec accoudoirs fixes gris ou réglables. Disponible en version à gaz ou a synchron.

Serie de sillas dactilo con plásticos grigie, respaldo alto con costuras. Base nylon gris de serie, y con base de aluminio disponible. Con brazos fijos grises o regulables. Disponible en versión a gas o a synchron

GOAL

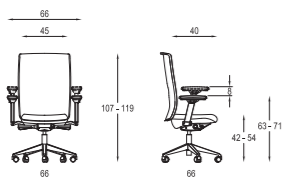

Seduta semidirezionale, con schienale alto, struttura in polipropilene nera. Schienale in rete, disponibile in 8 colori, o imbottito e rivestito, con supporto lombare regolabile, sedile imbottito in poliuretano espanso. Meccanismo sincron o traslatore. Braccioli fissi in polipropilene neri, o regolabili. Base a 5 razze in nylon nero o in alluminio pressofuso lucido, su ruote gommata e autofrenanti. Optional: appoggiatesta.

Task chair, high backrest, structure in black polypropylene. Backrest in mesh-net available in 8 colors, or padded and upholstered, with adjustable lumbar support; seat padded and upholstered. Synchronized mechanism or with slidesystem. Fixed black polypropylene armrests or adjustable. 5-star black nylon base or in aluminum on rubber and self-braking castors. Optional: headrest.

Siège de travail avec un design innovant. Elle offre le maximum du confort et elle se distingue pour sa versatilité. Avec le dossier en resille, disponible en 8 couleurs ou rembourré et le support lombaire réglable en hauteur, assise rembourrée. Mécanisme synchron, disponible avec réglage de profondeur. Base en nylon noir ou en aluminium, sur roulettes. Accessoires: appuie-tête, accoudoirs réglables.

Silla operativa, caracterizada por una linea ligera, estructura de polipropileno negro. Respaldo de rejilla, en 8 colores, o acolchado y tapizado, con soporte lumbar ajustable, y asiento acolchado. Base de nylon negro o en aluminio a 5 radios y con ruedas engomadas. Mecanismo sincronizado o con ajustador de profundidad. Brazos ajustables o fijos de polipropileno negro. Accesorio: apoyacabeza.

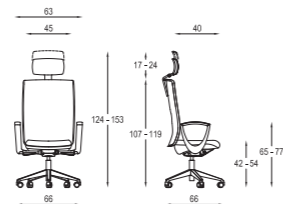
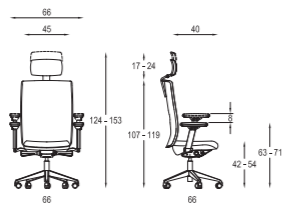
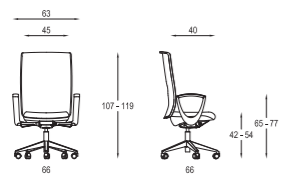

Linea di sedute dalle forme originali ed eleganti. La poltrona presidenziale è caratterizzata da uno schienale molto importante e dotata di un meccanismo sincronizzato auto pesante, che regola autonomamente l'intensità dell'oscillazione in funzione del peso corporeo dell'utilizzatore. La versione meeting e visitatore presenta uno schienale basso ed è disponibile su base a 5 razze in alluminio, oppure su telaio 4 lame con meccanismo di ritorno in posizione, ideale per le sale riunioni, o ancora su telaio slitta. Due varianti di bracciolo: totalmente imbottiti per una variante più classica o in alluminio lucidato.

An original and stylish seating range. The high-backed executive armchair features a striking back and a synchronized weight-based mechanism which automatically adjusts the intensity of tilt according to the user's bodyweight. The meeting and visitor version has a lower back and is available on a 5-spur aluminium base; or on a 4-blade base with swivel and ping-back mechanism, ideal for boardrooms; or on a sled base. Two types of armrest are possible: fully upholstered or in polished aluminium.

Ligne de fauteuils aux formes élégantes. Le fauteuil «Président» a un dossier très haut, équipé d'un mécanisme de synchronisation qui règle automatiquement la force de l'oscillation en fonction du poids du corps de l'utilisateur. Versions réunion et visiteur avec un base en aluminium à 5 branches ou un piétement à 4 branches avec mécanisme à retour automatique ou sur piétement luge. Deux variantes d'accoudoirs sont proposées: une version entièrement rembourrée ou une version en aluminium poli.

Linea de sillas elegantes y originales. La silla presidencial tiene un respaldo alto y un mecanismo de auto regulacion de peso, o sea la intensidad de regulacion del respaldo es automatica segun el peso del usuario. Hay la version reunion y confidente con base 5 radios y ruedas o con 4 radios y mecanismo de retorno o con base trineo cromada. dos diferentes tipologias de brazos: acolchados o de aluminio.

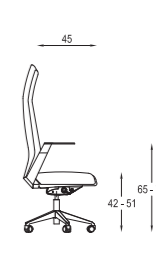
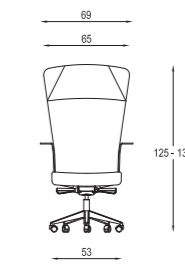
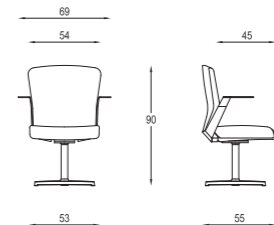
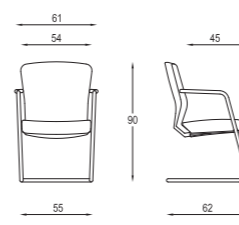
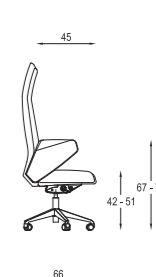
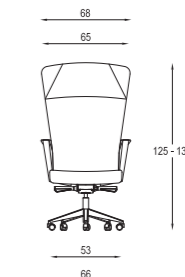
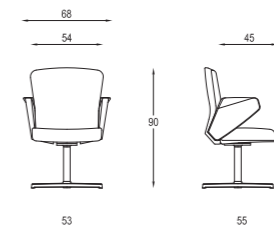
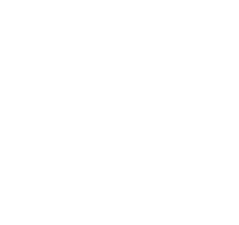

HALFPIPE

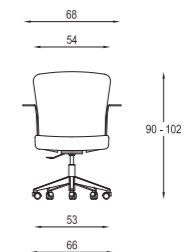
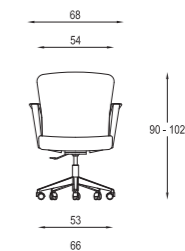



ICE

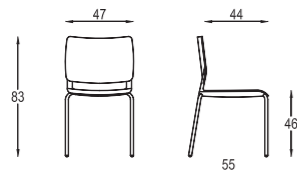

Seduta visitatore, in polipropilene colorato. Telaio 4 gambe cromato. Optional: sedile imbottito e rivestito, braccioli fissi e tavoletta scrittoio. Impilabile.

Visitor chair, in polypropylene. 4 legs chromed frame. Optional: seat padded in polyurethane foam and upholstered, fixed arms, writing tablet. Stackable.

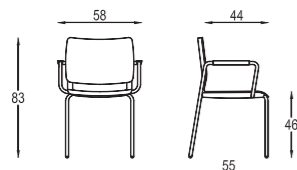

Chaise visiteur, en polypropylène. Structure en acier chromé, 4 pieds. Optional: seance rembourré en polyuréthane, accoudoirs et tablette écriteire. Empilable.

Silla confidente, respaldo en polipropileno negro o blanco, asiento acolchado en poliuretano. Estructura 4 patas cromadas. Accesorios: asiento acolchado y tapizado, brazos y mesa escritorio. Apilable.

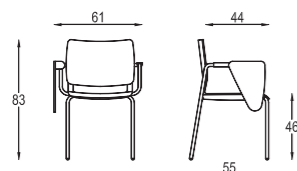

JAZZ

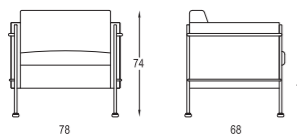

Poltrona 1 posto, divano 2 e 3 posti. Struttura in legno e acciaio cromato lucido, imbottitura in poliuretano espanso e piedini in acciaio cromato lucido.

Armchair, 2 and 3 seater sofa. Internal structure in wood and external structure in chromed polished steel. Padded in polyurethane foam and chromed steel feet.

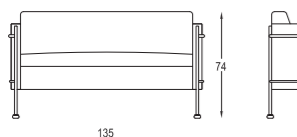

Fauteuil, canapé de 2 et 3 places. Coque de l'assise et du dossier en bois multiplis. Structure exterior en acier chromé poli. Rembourrage de polyuréthane, piétement en acier chromé poli.

Butaca, sofa de 2 plazas y de 3. Estructura interior de madera y exterior de acero cromado. Acolchado en poliuretano, con pies de acero cromado.

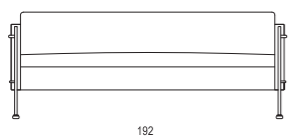

KEY

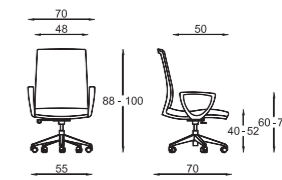

Visitor armchair, comfortable and versatile, perfectly suited to different working environment. Backrest in 8 colors of mesh, seat padded and upholstered. 5-star black nylon or aluminium base, or with cantilever chromed frame. Fixed black or white polypropylene armrests.

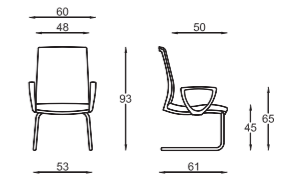

Silla de diseño elegante para, comfortable y muy versátil, perfecta para diferentes entornos de trabajo. Caracterizado por un respaldo de malla disponible en 8 diferentes colores, y un asiento acolchado de poliuretano. Brazos fijos de polipropileno negro o blanco.

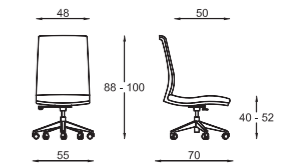

LIZ

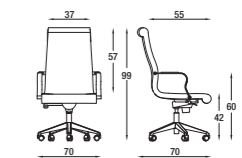

Executive armchair, extremely comfortable. Multilayer beech wood shell, padded in polyurethane foam. Kneetilt mechanism on 5 star aluminium base on rubber castors. With fixed chromed armrests or fixed padded and upholstered armrests. Mid backrest is available even with 4 aluminium blades frame, with return mechanism.

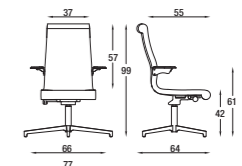

Silla de directivo, caracterizada por una linea elegante y ergonomica. Estructura de madera de haya y acolchada. Mecanismo knee-tilt con base de aluminio 5 radios y ruedas. Los brazos son fijos y cromados o acolchados y tapizados. La silla con respaldo medio puede tener la base de 4 radios en aluminio, giratoria con retorno automatico.

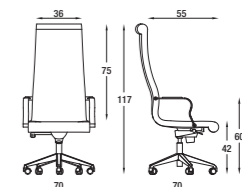

**LIZ**

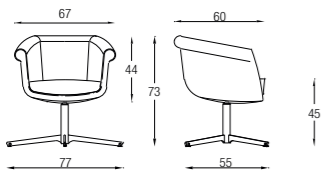

Seduta ideale per il settore casa e contract, monoscocca in schiumato a freddo, disponibile su telaio a 4 razze in alluminio con meccanismo di autoritorno o su base a 5 razze in alluminio pressofuso lucido con ruote ed elevazione a gas.

Armchair ideal for home and contract. Shell in steel and padded in injected foam on swivel 4 blades aluminium frame with return mechanism or on 5 star aluminium base with castors and gaslift.

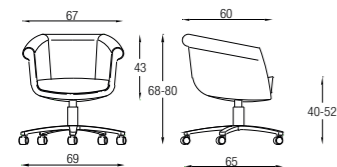

Petit fauteuil pour salles d'attente et réunion avec mécanism à gaz ou 4 rayons en acier chromé avec mécanisme de retour automatique. La structure est en acier avec rembourrage écumé à froid.

Sillón para la sala de espera y sala de reunión, en acero con acolchado de espumado a frío. Estructura de 4 radios de aluminio con mecanismo de retorno automatico, o con mecanismo a gas y base a 5 radios en aluminio con ruedas.

**LIZ**

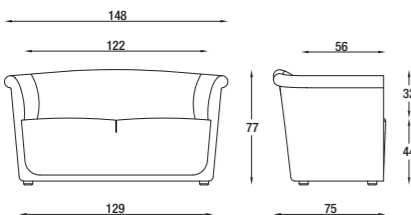

Poltrona 1 posto e divano 2 posti, dalle linee eleganti. Struttura interna in legno e imbottitura in poliuretano espanso. Piedini in polipropilene nero.

Armchair, and 2 seater sofa. Internal structure in wood, padded in polyurethane foam. Feet in black polypropylene.

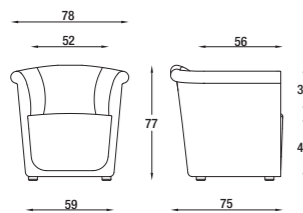

Fauteuil et canapé de 2 places. Coque de l'assise et du dossier en bois multiplis. Rembourrage de polyuréthane. Piètement en polypropylène noir.

Butaca y sofá de 2 plazas. Estructura interior de madera. Acolchado en poliuretano. Pies de polipropileno negro.

**MARVEL**

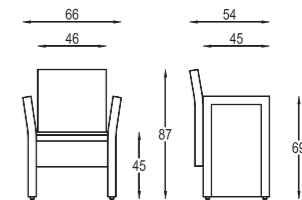

Pozzetto, ideale per sale riunioni e d'aspetto. Inerno in acciaio e imbottitura in schiumato a freddo, con braccioli. Su ruote o piedini.

Tub chair, perfect for meeting and waiting rooms. Inner structure in steel and padding in injected foam, with armrests. On feet or castors.

Fauteuil à la forme linéaire et élégant. Strcture en acier, mousé à froid. Sur roulettes ou pieds.

Butaca, perfecta por mesas de reunion y espera. Estructura de acero y acolchado de poliuretano inietado. Con brazos. En ruedas o pies.

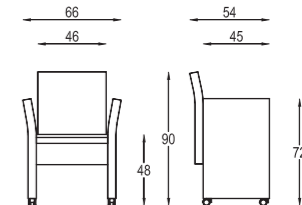

**MISS**

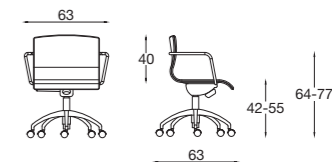

Serie di poltroncine caratterizzate da una linea sinuosa ed essenziale, di spiccata versatilità, ideale per la casa, il contract e l'ufficio. La monoscocca è in multistrato di faggio, imbottita e rivestita. La base può essere girevole su ruote con elevazione a gas o meccanismo knee-tilt, o su telaio girevole tubolare o 4 lame in alluminio ad altezza fissa e meccanismo di autoritorno, o ancora su telaio a 4 gambe cromato o su slitta cromata. Con o senza braccioli in tubolare cromato.

Range of armchairs characterized by a simple, curved design, highly versatile, ideal for the home or office. The shell is in multilayer beech wood, padded in polyurethane and upholstered. The base is available on 5 star base on castors with gaslift or knee-tilt mechanism, or on 4 blades aluminium frame with return mechanism, or on 4 blades tubular chromed frame, or on 4 legs chromed frame or again on chromed sled frame. With or without chromed tubular armrests.

Série de petits fauteuils caractérisés par une ligne sinuouse et essentielle, d'un éclectisme marqué, idéale pour la maison, le contract et le bureau. La monocoque est en hêtre multicouche, rembourré et revêtu. La base peut être tournante sur roues avec élévation à gaz ou mécanisme knee-tilt, ou avec 4 rayons en acier tubulaire ou 4 rayons en aluminium avec mécanisme de retour automatique, ou sur 4 pieds fixes ou sur traîneau. Avec ou sans accoudoirs en acier tubulaire chromé.

Serie de sillas caracterizada por una línea sinuosa y esencial, de sobresaliente versatilidad, ideal por la casa, el contract y el despacho. La carcasa es de madera de hay, acolchada y tapizada. La basa puede ser de 5 radios con ruedas y elevacion a gas o mecanismo knee-tilt, o con estructura giratoria en tubular de acero cromado o 4 radios de aluminio y mecanismo de retorno automatico, o de 4 pies fijos o de trineo cromado. Con o sin brazos de acero cromados.

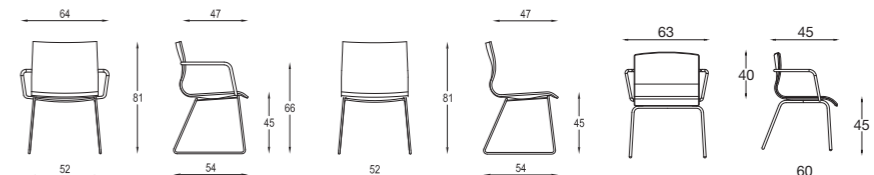

**MISS LOUNGE**

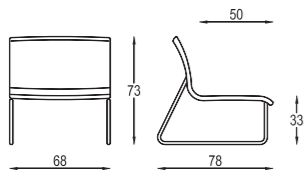

Poltrona lounge, struttura interna in multistrato di faggio, imbottitura in poliuretano espanso. Telaio slitta cromato.

Lounge chair, inner structure in multilayer beech wood, padded in polyurethane foam. Chromed sled frame.

Fauteuil lounge, coque en hêtre, rembourée en polyuréthane. Structure chromé, sur patin.

Sillon lounge, carcasa de madera de haya y acolchado de poliuretano. Estructura de acero cromado.

Poltroncina dalla forma elegante ed essenziale giusta alternativa alla tradizionale poltrona per visitatore. Con struttura in multistrato di faggio e barre in acciaio indeformabile. Può essere completamente rivestita con tessuto o pelle.

Compact elegant yet simple armchair, a perfect alternative to the traditional visitors' armchair. With a multilayered beech and non-deformable steel bar construction. It can be completely covered in fabric or leather.

**MISTER**

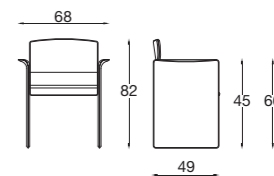

Petit fauteuil à la forme élégante et essentielle, alternative au fauteuil traditionnel pour visiteur. Avec structure en hêtre multicouche et barres en acier indéformable. Il peut être complètement revêtu en tissu ou en cuir.

Sillón de la forma elegante y esencial justa alternativa al tradicional sillón para visitador. Con estructura en multistrato de haya y barras de acero indeformable. Puede ser completamente revestida con tejido o piel.

**MISS PANCA**

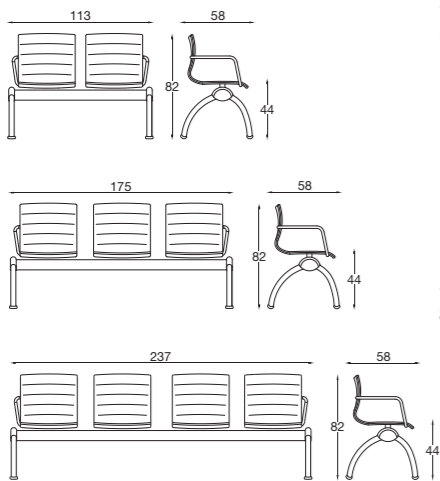

Seduta in multistrato di faggio, rivestita in tessuto o pelle con o senza cuciture trasversali, montata su barra nera con gambe in acciaio cromata da 2 a 5 posti.

Shell in multilayer beech wood, padded and upholstered. Chromed legs, beam available from 2 to 5-seater unit.

Séance en hêtre multi-couche et revêtue, avec pies en acier chromé. Disponible de 2 a 5 places.

Carcasa en multistrato de haya, acolchada y tapizada. Pies cromados. Bancada de 2 a 5 asientos.

Poltrona direzionale, caratterizzata dalle linee eleganti e dal massimo comfort. Telaio cromato a 4 razze, seduta girevole. Disponibile con base girevole in alluminio 5 razze, su ruote autofrenanti e gommate con meccanismo sincron. I braccioli sono in alluminio.

Executive armchair, extremely comfortable, on 4 chromed, swivel blade structure. Available on 5 star aluminium base on castors and synchronized mechanism, with aluminium armrests.

Série de fauteuils de direction ou de présidence, caractérisés par une ligne classique et élégante qui offre un confort maximum. Disponibles avec le base en aluminium; avec accoudoirs en aluminium.

Sillones directivos, caracterizados por una línea elegante. Con base de acero a 4 radios. Disponible con base de aluminio 5 radios y mecanismo sincronizado. Los brazos son en aluminio.

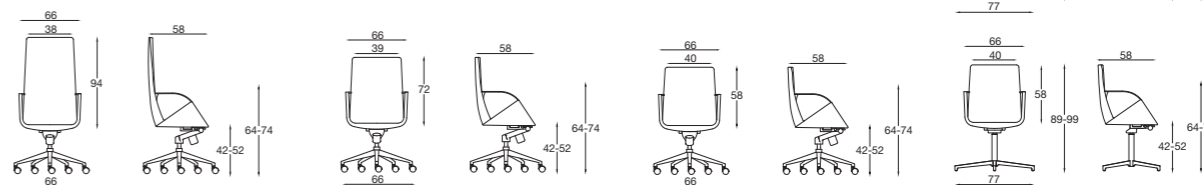

**MOON**

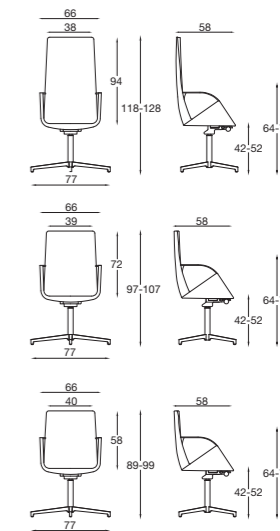

**NEST**

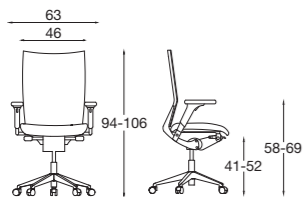

Poltrona direzionale con schienale con struttura in alluminio pressofuso lucido in rete o in tessuto, supporto lombare regolabile, base in alluminio pressofuso lucido, meccanismo sincron, braccioli regolabili in altezza con supporto in alluminio pressofuso lucidato.

Executive chair, high backrest with polish aluminium with mesh net or fabric, seat in polyurethane padding, lumbar support adjustable in height. Aluminium 5 star base on castors, synchron mechanism, adjustable arms.

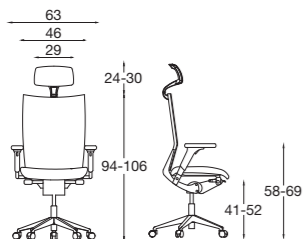

Fauteuil directionnel. Elle offre le maximum du confort. Le dossier avec structure en aluminium, le support lombaire réglable en hauteur. Base en aluminium, avec accoudoirs.

Silla de directivos, respaldo alto con estructura de aluminio y red o tejido, asiento acolchado en poliuretano y soporte lumbar ajustable en altitud. La base es en aluminio a 5 radios y con ruedas, mecanismo sincron, brazos ajustables.

**ORIGAMI**

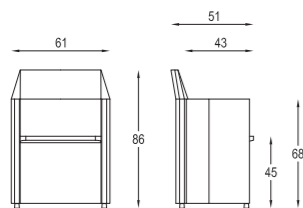

Pozzetto, ideale per sale conferenze, riunioni e d'aspetto. Inerno in acciaio e imbottitura in schiumato a freddo. Richiudibile e impilabile orizzontalmente. Su ruote o piedini. Optional: tavoletta scrittoio.

Tub chair, perfect for conference, meeting and waiting rooms. Inner structure in steel and padding in injected foam. Completely foldable and stackable in horizontal way. On feet or castors. Optional: writing tablet.

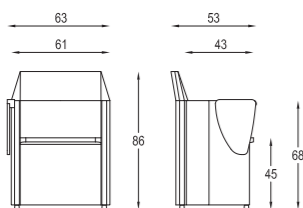

Petit fauteuil pour salles de conférence et réunion. Structure en acier moussé à froid, assise pliant et empilable horizontalement. Sur roulettes ou pieds. Disponible avec tablette écriteoire.

Butaca, perfecta por salas de conferencia, mesas de reunion y espera. Estructura de acero y acolchado de poliuretano inyectado. Pliable y apilable horizontalmente. Con ruedas o pies. Opcional: mesa escritorio.

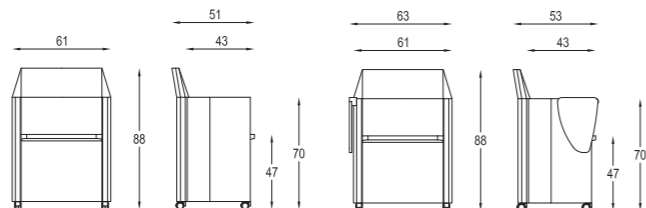

Sistema di sedute e piani a 2 e 3 posti, ideale per sale formazioni, auditorium e aule università, con sedile ribaltabile. Versione in legno verniciato naturale o imbottita e rivestita.

2 or 3-seater seating system with writing boards, perfect for training rooms, auditoriums or university spaces, with tip up seat. Available in multilayer beech wood, with tip up seat. Available in multilayer beech wood, natural painted, or padded and upholstered version.

Système d'assises et bancs de 2 et 3 places, idéal pour les salles de formation, les auditoriums et les salles de classe des universités, avec assise pliant. Version en bois verni ou rembourrée et revetue.

Sistema de asientos de 2 o 3 plazas y mesas escritorios, perfecto para salas de fomacion o universidades, con asiento plegable. Hay la version de madera varnizada natural o la version acolchada y tapizada.

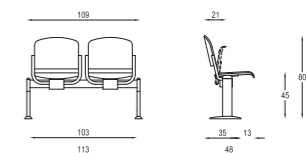
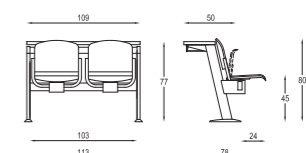
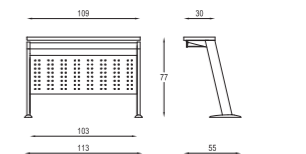
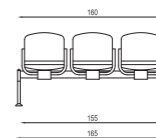
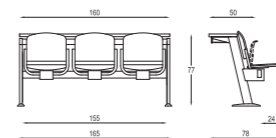
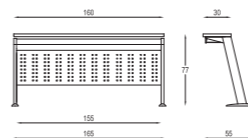

**OXFORD**

**PASS**

Pozzetto, ideale per sale riunioni e d'aspetto. Inerno in legno con imbottitura in poliuretano espanso, con braccioli. Su ruote o piedini.

Tub chair, perfect for meeting and waiting rooms. Inner structure in multilayer beech wood and padding in polyurethane foam, with armrests. On feet or castors.

Petit fauteuil à la forme linéaire pour salles d'attente et réunion. Structure en bois, rembourrée en mousse polyuréthane. Sur roulettes ou pieds.

Butaca, perfecta por mesas de reunion y espera. Estructura de madera y acolchado de poliuretano. Con brazos. En ruedas o pies.

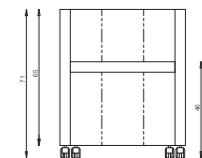
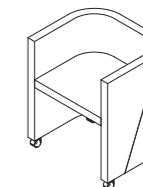

PRINCE

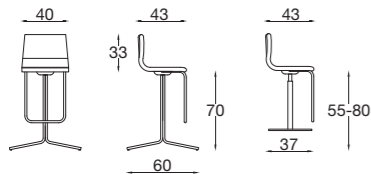

Sgabello dalla linea morbida e sinuosa, con monoscocca in multistrato di faggio con schienalino alto o basso, rivestimento in pelle e tessuti. Disponibile nella versione con elevazione a gas e base tonda, oppure su telaio in tubolare d'acciaio cromato a quattro razze. Su tutti viene montato un appoggiatesta in tubolare d'acciaio.

Stool with a soft, curved design, in multilayered beech with high or low backrest. Available with gas height adjustment and with a round chromed base, or on a tubular chromed steel frame with four blades. Feetrest in tubular chromed steel.

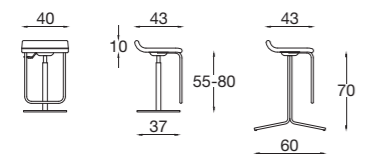

Tabouret à la ligne souple et sinueuse avec monocoque en multicoque de hêtre avec petit dossier haut ou bas. Disponible dans la version avec élévation à gaz et base ronde chromée ou sur structure en acier tubulaire chromé à quatre rayons. Un repose-pied en acier tubulaire chromé est monté sur tous les modèles.

Taburete de línea sinuosa, carcasa en multistrato de haya con respaldo alto o bajo. Disponible en la versión con elevación a gas y base redonda cromada, o bien con telar en tubular de acero cromado a cuatro radios. El apoyapiés es en tubular de acero.

QUEEN

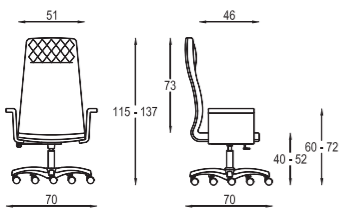

Sedia direzionale e presidenziale, con scocca in multistrato di faggio e imbottitura in poliuretano espanso, con extra imbottitura su seduta e poggiatesta in Memory Foam. Meccanismo alzata a gas o knee-tilt. Base a 5 razze in nylon nero o in alluminio su ruote gommata e autofrenanti. Braccioli fissi in nylon nero o imbottiti e rivestiti.

Executive and presidential office chair, shell in multilayer beech wood, padded in polyurethane foam and extra padding on seat and headrest in memory foam. Gaslift or knee-tilt mechanism. 5-star black nylon base or in aluminium on rubber and self-braking castors. Fixed armrests in black nylon or padded and upholstered.

Ligne de fauteuils de direction ou de présidence, caractérisés par une ligne classique et élégante. Coque en hêtre, rembourrée en polyuréthane et avec un extra rembourrage sur seance et sur appui-tête en Memory foam. Disponibles avec mécanisme à gaz ou synchron; option d'accoudoirs rembourré ou fixes en nylon. Base à 5 rayons en nylon ou aluminium, sur roulettes.

Sillon de directivos, respaldo medio o alto, estructura de madera de haya, acolchado de poliuretano e memory foam en el asiento y en el reposacabeza. Mecanismo de gas o knee-tilt. Base a 5 radios de polipropileno negro o de aluminio con ruedas engomadas. Brazos fijos de nylon negro o acolchados y tapizados.

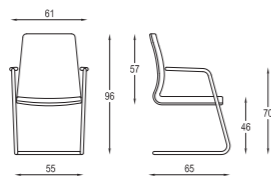
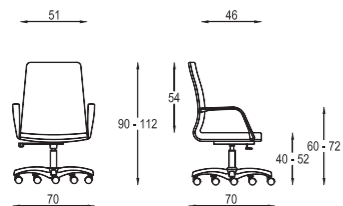

Sedia operativa, base nylon nera di serie, con braccioli fissi o senza braccioli. Disponibile in versione a gas contatto permanente o sincron.

Ligne de chaise pour bureau dactyle. La base est en nylon noir, avec accoudoirs fixes ou sans accoudoirs. Disponible en version à gaz ou synchron.

Seduta semidirezionale, con schienale alto, struttura in polipropilene bianca o nera. Schienale in rete, disponibile in 8 colori, con supporto lombare regolabile, e sedile imbottito in poliuretano espanso. Meccanismo sincron. Braccioli fissi in polipropilene bianchi o neri, o regolabili. Base a 5 razze in nylon nero o in alluminio pressofuso lucido, su ruote gommata e autofrenanti. Optional: appoggiatesta e cuscino schienale imbottito e rivestito.

Fauteuil directionnelle avec un design innovant. Elle offre le maximum du confort et elle se distingue pour sa versatilité. Avec le dossier en resille, disponible en 8 couleurs et le support lombaire réglable en hauteur, seance rembourrée. Mécanisme synchron. Base en nylon noir ou en aluminium, sur roulettes. Accessoires: appui-tête et coussin de dossier.

Task chair, with standard black nylon base. With fixed arms or without arms; with permanent contact gas-lift or synchron mechanism.

Serie de sillas dactilo. Base nylon negra. Con brazos fijos o sin brazos. Disponible en versión gas o synchron.

Executive chair, high backrest, structure in white or black polypropylene. Backrest in mesh-net available in 8 colors, with adjustable lumbar support; seat padded and upholstered. Synchronized mechanism. Fixed black or white polypropylene armrests or adjustable. 5-star black nylon base or in aluminum on rubber and self-braking castors. Optional: headrest and cushion padded and upholstered for backrest.

Silla de directivos, caracterizada por una linea ligera, estructura de polipropileno negro o blanco. Respaldo de rejilla, en 8 colores, con soporte lumbar ajustable, y asiento acolchado y tapizado. Base de nylon negro o en aluminio a 5 radios y con ruedas engomadas, con mecanismo sincronizado. Brazos ajustables en acero y polipropileno o fijos de polipropileno negro o blanco. Accesorio: apoyacabeza y cojin para respaldo.

RING

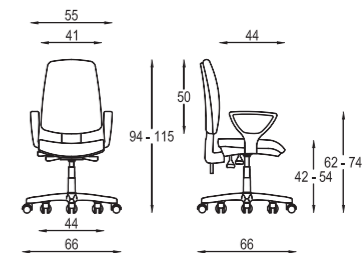
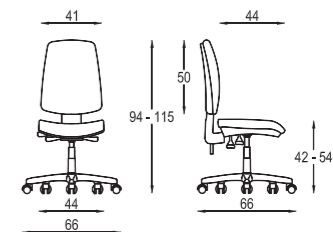

SMART

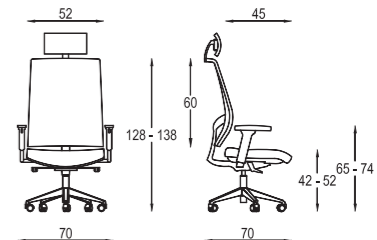
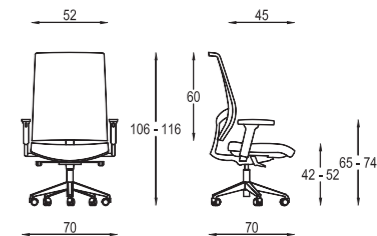

**SOCIAL**

Seduta visitatore, schienale imbottito in poliuretano espanso o in rete, sedile imbottito e rivestito. Telaio slitta cromato o 4 gambe, con braccioli fissi e copribraccioli in polipropilene nero. Impilabile.

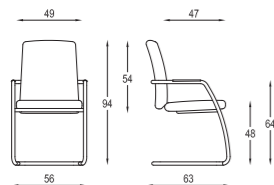

Siège visiteur, dossier haut rembourré en polyuréthane ou dossier bas en resille, assise en polyuréthane revetue. Structure patin chromé ou 4 pieds, avec accoudoirs fixes. Empilable.

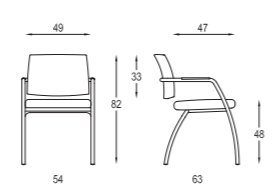
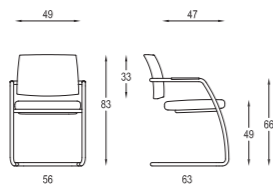
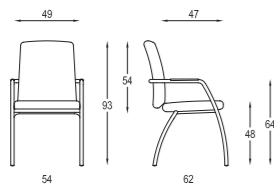

Visitor chair, backrest padded in polyurethane foam and upholstered or in mesh net, seat padded and upholstered. Chromed cantilever frame or 4 legs, with fixed arms and cover arms in polypropylene. Stackable.

Silla confidente, respaldo acolchado y tapizado o de rejilla, asiento acolchado y tapizado. Estructura cromada trineo o 4 patas, brazos fijos. Apilable.

**SQUARE**

Divano composto da basi per singola o doppia seduta, versatile in quanto componibile e adattabile a qualsiasi tipo di spazio ed esigenze. Struttura portante in legno e pannelli in agglomerato di legno rivestito con poliuretano espanso indeformabile e tessuto protettivo accoppiato. Il meccanismo di molleggio della seduta è composto da cinghie elastiche. Il rivestimento del divano può essere in tessuto completamente sfoderabile o in pelle, non sfoderabile. I cuscini hanno un'imbottitura di gommapiuma e sono rivestiti in tela di cotone.

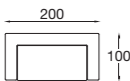

Canapé composé avec bases pour individuelle ou double séance, éleclétique puisque encastrable et adaptable à n'importe quel type d'espace et exigence. Structure en multiplis et bois aggloméré recouvert d'une mousse indéformable de polyuréthane et doublée de fibres de polyester. Le mécanisme est composé de sangles élastiques qui permettent un meilleur confort. Le revêtement peut être en tissu, complètement amovible ou en peau fixed. Les coussins décoratifs sont en "multifill" et recouverts d'une doublure protectrice en coton.

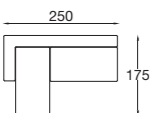
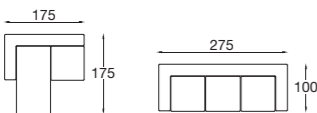

Sofa composed of bases for single or double seater, adaptable to any type of space and requirements. Wooden frame with beech multiply panels upholstered in non-deformable polyurethane foam and lined in protective polyester. The mechanism is made up of elastic belts to enhance comfort. Can be upholstered either with removable fabric covers or non-removable leather. The cushions are made of multifill and covered in a protective cotton lining.

Sofá compuesto por bases de uno o dos asientos, versátil en cuánto componible y adaptable a cualquier tipo de espacio y exigencias. Estructura portante de madera y paneles en multistrato revestido con poliuretano esponjoso indeformable y tejido protectorio junto. El mecanismo de muelle del asiento está compuesto por correas elásticas. La tapicería del sofá puede ser en tejido completamente desfundable o en piel, no desfundable. Los cojines tienen un acolchado a caucho esponjoso y el tejido ed de algodón.

Poltrona direzionale e presidenziale dal design innovativo. Offre il massimo comfort e una spiccata versatilità. Con schienale in rete nera, con supporto lombare regolabile in altezza; seduta imbottita e rivestita; braccioli fissi o regolabili, meccanismo d'elevazione sincronizzato. La base è in alluminio pressofuso lucido.

Fauteuil directionnel et présidentiel avec un design innovant. Elle offre le maximum du confort et elle se distingue pour sa versatilité. Avec le dossier en filet et le support lombaire réglable en hauteur. Avec accoudoirs fixes ou réglables.

Innovatively designed armchair for managers and executives, offering maximum comfort and striking versatility. Black mesh backrest, with adjustable lumbar support; upholstered seat, fixed armrests and synchron gas-lift. The base is in polished die-cast aluminium. With fixed or adjustable arms.

Sillón direccional y presidencial de diseño innovativo. Ofrece el máximo confort y una sobresaliente versatilidad. Con respaldo en red negra, con soporte lumbar ajustable en altura; asiento acolchado y tapizado; brazos fijos o ajustables, mecanismo de elevación sincronizado. La base está de aluminio brillante.

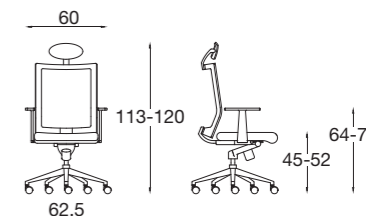
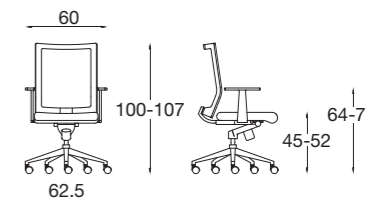

**STAR**

Poltroncina visitatore con telaio in acciaio cromato 4 gambe, con inserti in alluminio. Schienale in rete indeformabile nera e seduta imbottita. Con braccioli.

Petit fauteuil pour visiteur avec une châssis en acier chromé à 4 pieds et éléments en aluminium. Dossier en filet indéformable noir et séance rembourrés. Avec accoudoirs.

Visitors armchair with 4 legs chromed metal frame. Back rest in non-deformable black mesh-net, with upholstered seat.

Silla visitador con telar de acero cromadas 4 pies, con legajos de aluminio. Respaldo en red indeformable negra y asiento acolchada. Con brazos

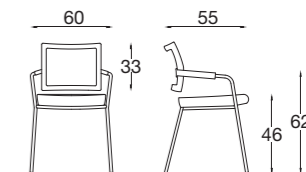

**STAR**

**STYLE**

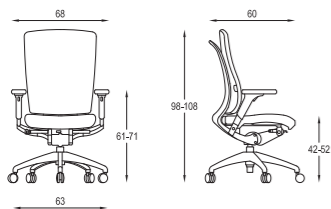

Seduta direzionale, con schienale ergonomico, dotato di supporto lombare regolabile in altezza, imbottita in schiumato a freddo, meccanismo sincron con traslatore, braccioli regolabili in altezza e orientabili in poliuretano morbido, e base a 5 razze in alluminio pressofuso lucido, su ruote. Disponibile la versione con appoggiatesta.

Executive chair, high backrest with lumbar support adjustable in height, injected foam padding, synchronized mechanism and slidesystem, adjustable armrests and 5 star polish aluminium base on castors. Available with headrest.

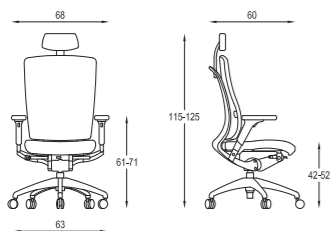

Fauteuil directionnel, avec structure indéformable en mousse à froid, le support lombaire réglable en hauteur. Base en aluminium, avec accoudoirs réglables. Disponible avec repose-tête.

Silla de directivos, caracterizada por una linea ligera. Acolchada en espuma fría, la base es en aluminio a 5 radios y con ruedas, mecanismo sincronizado y adelantamiento del asiento, brazos ajustables en acero y poliuretano. Disponible con reposacabeza.

**SUNNY**

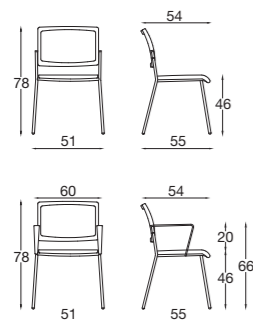

Seduta per la collettività, telaio 4 gambe verniciato nero o cromato, versione su gas e base a 5 razze con ruote, schienale in polipropilene bianco, in rete nera o imbottito e rivestito, la seduta è sempre imbottita e rivestita. I braccioli sono neri in poliuretano morbido, possibilità di tavoletta scrittoio e agganci fissi. Disponibile anche su panca.

Conference chair, black painted or chromed 4 legs frame, seat padded in polyurethane and upholstered, backrest in white polypropylene, in black mesh-net or upholstered, with black soft polyurethane arms, writing desk and linking available. Version on gaslift and 5 star base on castors and on bench.

Siège pour salle de conférence, châssis à 4 pieds chromé ou peint en noir, dossier en filet indéformable noir, ou en polypropylène blanc, ou revêtue et séance rembourrés. Disponible aussi avec accoudoirs noir, et tablette écrioire.

Silla para colectividad, con estructura 4 patas barnizada negra o cromada, asiento acolchado en poliuretano y tapizado, respaldo en polipropileno blanco o en rejilla negra o tapizado. Version con mecanismo de gas y base con ruedas, y en bancada.

**TOFFEE**

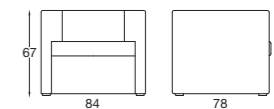

Single-seater waiting room armchair, two or three-seater sofa with structure in multilayer beech wood, padded in polyurethane. Veneered wood feet.

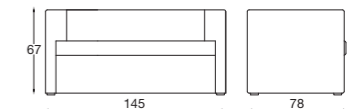

Sillón para la sala de espera o sofá de 2 asientos con estructura en multistrato de haya, acolchado en poliuretano esponjoso. Pies de madera pintado negro. Disponible también en versión de 3 asientos.

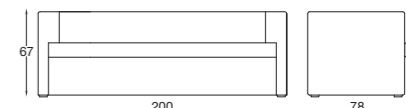

**TRONIX**

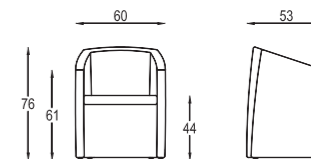

Stylish tub armchair, perfect for any environment: offices, meeting rooms, waiting rooms and hotels. Structure in steel and padded in injected foam. Available on castors or with fixed feet. Optional writing tablet is available.

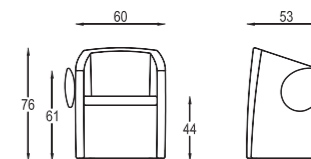

Butaca linear y elegante; ideal para cualquier ambiente: oficinas, salas de reuniones, salas de espera y hoteles. Estructura de acero, acolchado de poliuretano espumado a frío, disponible con ruedas o pies fijos. Opcional: pala para escribir.

Poltrona d'attesa o divano 2 posti con struttura in multistrato di faggio, imbottitura in poliuretano espanso. Piedini in legno verniciato nero. Disponibile anche in versione 3 posti.

Fauteuil pour salle d'attente ou canapé à 2 places avec une structure en hêtre multi-couche, rembourrage en polyurethane expansé. Petits pieds en acier chromé. Aussi disponible en version à 3 places.

Pozzetto, dalla forma lineare ed elegante; ideale per qualsiasi ambiente: ufficio, sale riunioni, sale d'attesa ed alberghi. Con struttura indeformabile in acciaio schiumato a freddo, disponibile su ruote o piedini fissi. Opzionale: tavoletta con snodo antipanico.

Fauteuil à la forme linéaire et élégante; idéale pour bureau, salles réunions, salles d'attente et hôtels. Avec structure indéformable en acier moussé à froid, disponible sur roues ou petits pieds fixes. Opzionale: tablette écrioire.

**VANITY**

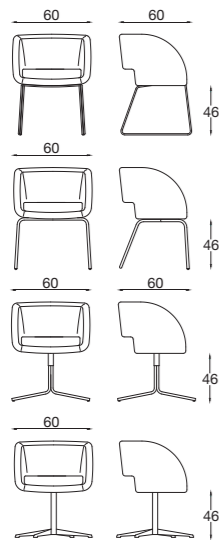

Poltroncina d'attesa e riunione con meccanismo a gas e base 5 razze su ruote o su 4 gambe cromate o su telaio slitta o 4 razze in tubolare d'acciaio o 4 razze in alluminio con meccanismo di autoritorno. Struttura in acciaio con imbottitura in schiumato a freddo.

Waiting and meeting armchair, with structure in steel and padded in injected foam. Available with gaslift mechanism and 5-star base on castors, or on 4 legs, or chromed sled frame, or chromed 4 blades tubular frame or 4 blades in aluminium with return mechanism.

Petit fauteuil pour salles d'attente et réunion avec mécanisme à gaz ou sur châssis glisse, ou 4 pieds, ou 4 rayons en acier tubulaire ou 4 rayons en aluminium avec retour automatique. La coque est en acier avec rembourrage écumé à froid.

Silla para salas de espera y salas de reunión con mecanismo a gas o telar trineo, o 4 pies cromados, o 4 rayas de acero tubular o 4 rayas de aluminio con retorno automatico. Estructura de acero con acolchado de espumado a frío.

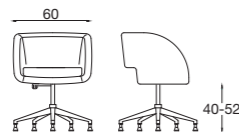

**VENUS**

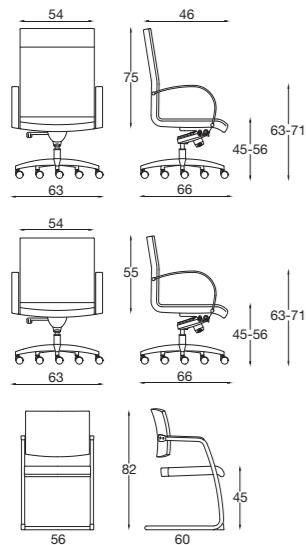

Serie di poltrone presidenziali e direzionale caratterizzate dalle linee eleganti e dal massimo comfort. Disponibile con base girevole in alluminio 5 razze, su ruote autofrenanti e gommate con meccanismo knee-tilt o con basamento slitta per la sedia visitatore. I braccioli sono in acciaio e imbottiti.

Range of armchairs for managers and top executives extremely comfortable, characterised by a classical design. 5 star aluminium base on castors and kneetilt mechanism, or visitor chair in cantilever chromed frame.

Série de fauteuils de direction ou de présidence, caractérisés par une ligne classique et élégante qui offre un confort maximum. Disponibles avec les rayons tournants ou avec base a coulisse en métal; il peuvent avoir l'accoudeur avec une partie rembourrée.

Sillones presidenciales y directivos, caracterizados por una linea elegante. Con base de aluminio a 5 radios, ruedas engomadas, mecanismo knee-tilt o estructura cantilever para la silla confidente. Los brazos son en acero y acolchados.

**YOGA**

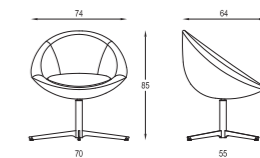

Poltrona da attesa, con struttura interna in acciaio e imbottita in schiumato a freddo, telaio in alluminio a 4 razze, con meccanismo di autoritorno.

Armchair with internal structure in steel and padded with injected foam, on swivel 4 aluminium blades frame with return mechanism.

Fauteuil, pour salles d'attente. La structure est en acier avec rembourrage écumé à froid. Piédment de 4 rayons en aluminium avec mécanisme automatique.

Butaca con estructura de acero y acolchada de poliuretano espumado a frío. Base a 4 radios en aluminio, mecanismo de autoretorno.

**YPSILON**

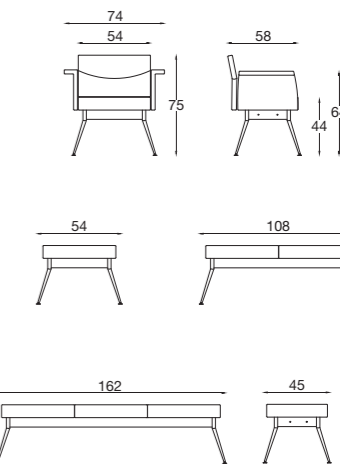

Poltroncina imbottita in versione singola, divanetto e panca con struttura portante in metallo cromato e sedute e braccioli in poliuretano espanso schiumato a freddo ignifugo.

Upholstered armchair available as a one, two or three seater, or with in-built coffee table. Chromed steel frame with seats and arms in fire retardant cold foamed resins.

Petit fauteuil en version individuelle, canapé et banc avec la structure portant en métal chromé et séances et accoudeurs en polyuréthane expansé écumé à froid.

Pequeño sillón acolchado versión individual, sofá y banco con estructura portante de metal cromado, asiento y brazos en poliuretano esponjoso espumado a frío ignifugo.

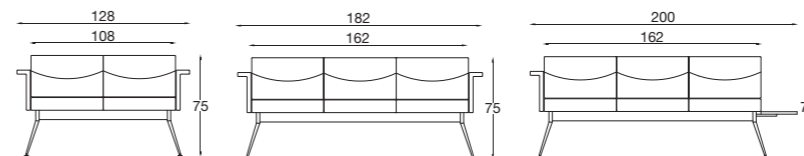

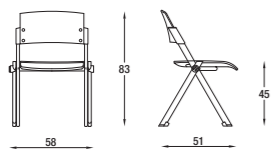

**ZETA**

Sedia ideale per la collettività, con o senza braccioli o con braccioli e tavoletta. Telaio 4 gambe verniciato grigio. Sedile imbottito e rivestito e schienale in polipropilene nero. Sedile ribaltabile, possibilità di impilare la sedia orizzontalmente.

Conference chair, with or without arms or with arms and tablet. 4 legs frame, aluminium color painted. Seat padded in polyurethane foam and upholstered. Foldable seat, stackable in an horizontal way.

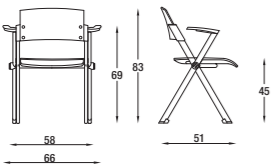

Chaise de conférence, avec ou sin accoudoir, ou avec accoudoir et tablette écriteiro. Séance rembourré et dossier en polypropylène noir. Seance pliant et la chaise est empilable horizontalement.

Silla para la comunidad y la espera, con o sin brazos o con brazos y mesa escritorio. Asiento acolchado y tapizado y respaldo en polipropileno negro. Asiento plegable y silla apilable horizontalmente.

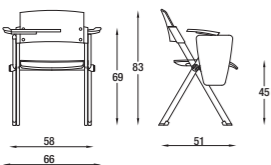

Fotografie: Gianni Sabbadin - Studio Nova

Fotolito: Bieffe - Studio Nova

Stampa: Grafiche Antiga

FEBBRAIO 2014

grafiche  
antiga

graficheantiga.it

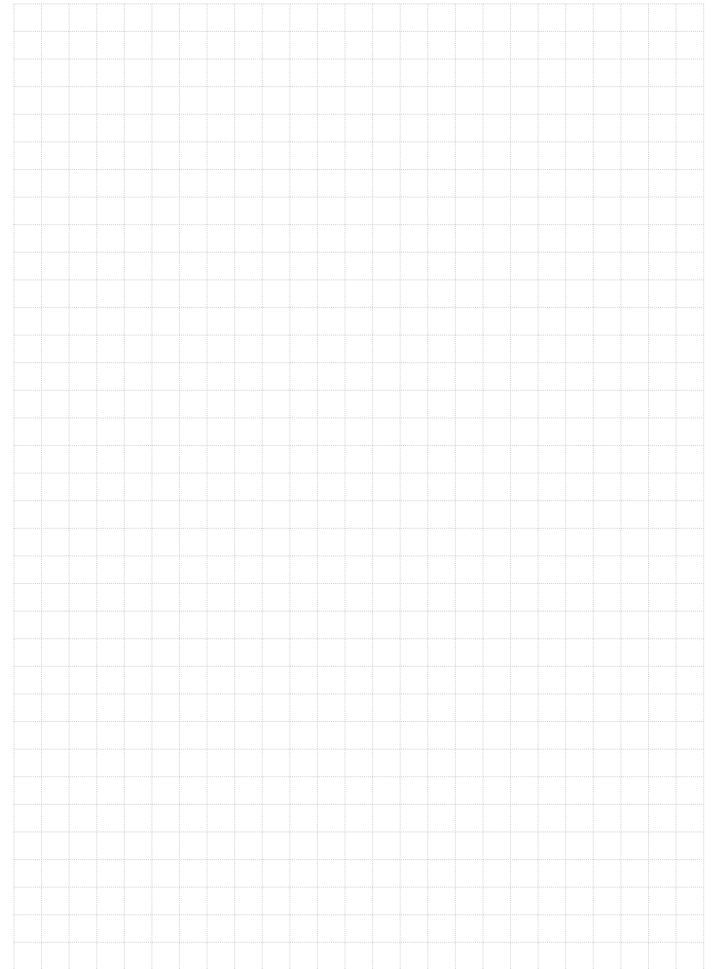



**D.M. snc**

**Sede legale:** Vicolo Sere, 16 - 31020 San Vendemiano (TV) Italy

**Sede operativa:** Via Bradolini, 52/A - 31020 Castello Roganzuolo - San Fior (TV) Italy

Tel. +39 0438 778211 - Fax +39 0438 479836

[www.diemmeoffice.com](http://www.diemmeoffice.com) - e-mail: [dm@diemmeoffice.com](mailto:dm@diemmeoffice.com)